

KEYENCE

NEW CV Series Vision Systems



CE

**More Speed. More Resolution.
More Solutions.**

Introducing the Most Versatile Machine Vision Systems in the Industry

VISION SYSTEM GENERAL CATALOG

The Evolution of KEYENCE Machine Vision Systems

KEYENCE has been an innovative leader in the machine vision field for more than 20 years. Its high speed and high performance machine vision systems have been continuously improved upon and now allow for even greater usability and stability when solving today's most difficult applications. The new CV-5000 Series is built upon years of experience and includes numerous innovations that have helped make KEYENCE a true industry leader. KEYENCE is committed to introducing new cutting-edge products that go beyond the expectations of its customers.



CAD Series
LED illumination units,
lenses, etc.



XV Series



The first image
processing sensor.

VX series



CV-300 Series



CV-100 Series



CV-500 Series



CV-700 Series

1980s

General-purpose image processing device is developed.

1990s

KEYENCE becomes the first company in the industry to introduce complete, low cost visual inspection systems. These general purpose sensors created a new market for user friendly vision systems.

2000

KEYENCE introduces the industry's first 2 camera, built-in monitor, all-in-one compact vision solution.



CV-3000 Series

CV-2100 Series

CV-2600 Series

Arrival of the CV-5000 Series

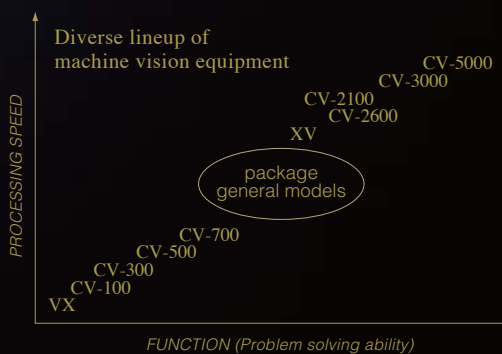

2003

High-speed general-purpose vision system incorporating twin processors and digital transfer camera is released.

2004

Package featuring 2 megapixels is released.

2005 to 2008

The CV-3000 and CV-5000 raise the bar for machine vision performance with 4 camera connectivity, unmatched speed, and the industry's most user friendly programming interface.

2009 and beyond

As the machine vision market expands, KEYENCE will use its vast experience and knowledge to continue to provide the industry with the most advanced technology available.

Product Overview

Machine Vision System

Ultra High-Speed, Multi-Camera Vision Systems

CV-5000 Series NEW ▷ P. 08



Multi-Camera Series ▷ P. 10

Expandable Controller Architecture ▷ P. 13

Ultra High-Speed Processing and New Color Extraction Engine, A.C.E.I.I ▷ P. 14

Defect Detection Solutions ▷ P. 16

Statistical Processing and Communication Software ▷ P. 23

Multiple Interface Options and Dimensions ▷ P. 26



All-in-One Image Processing

CV-700 Series ▷ P. 32

Illumination

LED Illumination

CA-D Series ▷ P. 36

Fluorescent Illumination

CV-R/CA-R Series ▷ P. 38



Lens Options

Macro Telecentric Lens

CA-LM Series ▷ P. 46

High-Resolution & Low Distortion

CA-LH Series ▷ P. 47

CCTV Lens

CV-L Series ▷ P. 48

Super Small Lens

CA-LS/CA-LHS Series ▷ P. 50



Monitors & Peripheral Equipment

LCD Color Monitor

CA-M Series ▷ P. 53

Color Monitor

CV-M Series ▷ P. 54

Camera Adjustment Stage

CA-S2040 Series ▷ P. 55



Applications

Part identification / Defect inspection

Measurement /

Automotive / Metal

Checking for adhering piston chips

Pass 

Fail  Chip



Formed-in-place gasket (FIPG) coating inspection

Pass 

Fail*  *Coating break



Identifying incorrect connecting rods

Pass 

Fail*  *Different diameter and overall length



Inspecting motor wire bundles and checking for solder defects

Pass 

Fail*  *Bundle defect



Camshaft mold cavity inspections

Pass 



Checking workpiece seating in hot-forging dies

Pass 

Fail*  *workpiece position drift





Food, Pharmaceutical & Others

Flaw inspection on the bottom of cans



Interior inspection of containers

Stain Seam

Label inspection (position/appearance)

Torn



Chip inspection on bottle rims

Chip



Detecting deformed cups





Dimensional measurement of bottle rims



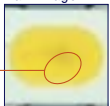

Electrical / Electronic

Visual inspection of chip (SMD) LEDs

Raw image 

Stain 

Filtered image 

The stain is stably extracted



Multi-directional inspection of electronic parts



Label inspection (position/appearance)



Visual inspection of a chip capacitor

Raw image 

Filtered image 



Visual inspection of crystal oscillators

Pass 

Adhesion and displaced cover 



A virtual circle is determined from the partial arc of a wafer to output the wafer center

New circle detection algorithm (trend edge tool)

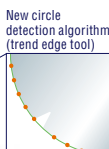
Positioning

Color inspection / OCR / Counting

Automotive / Metal

Food, Pharmaceutical & Others

Electrical / Electronic

Detecting bead positions



Random picking of bushing parts by robots



Checking improperly closed caps



Checking the liquid level



Dimensional/ Visual inspection of capacitors

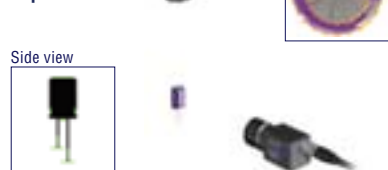

Simultaneous measurement of pitch and coplanarity



Detecting incorrectly assembled fuse boxes



Detecting amount of grease applied to parts



Inspection of expiration dates



Counting items in a carton



Character recognition of part numbers



Detecting BAT marks with red ink



Detecting wrong gears



Checking for missing O-rings or O-ring misalignment during EGR valve assembly



Counting the number of tablets



Type/Orientation differentiation of drink boxes



Checking orientation through embossed tape

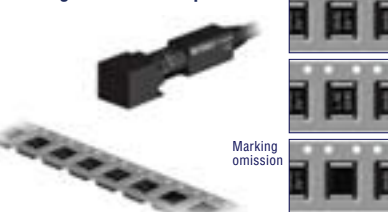

Checking the wafer position in a rack



CV-5000 Series

The industry's most state-of-the-art problem solving tool is now even better. Introducing the new CV-5000 Series, relentless in its ability to solve challenging applications.

BEST RESOLUTION IN ITS CLASS Ultra high-definition image processing is now available for any production line

11x high-speed, 5 million-pixel camera **11x 5MEGA DIGITAL** ▷ P. 10

The 11x high-speed camera transfers ultra high-definition, 5 megapixel images (2432 x 2050 pixels) in 61.2 ms (16.3 times/sec). High-speed production lines can now harness the benefits of high-precision image processing. The new CV-5000 Series accepts up to four 5 million-pixel cameras and transfers the images simultaneously, enabling high-definition inspections of up to 20 million pixels.

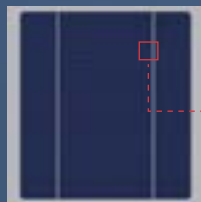

Broken pattern detected in a solar battery electrode

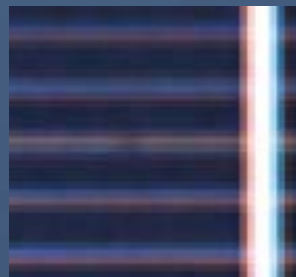

Conventional 310,000 pixel-camera
Defect cannot be recognized.

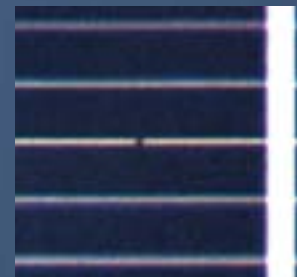

5 million pixel-camera
The broken pattern is clearly visible.

FASTEST IN ITS CLASS High-speed, parallel processing system

3+1 processor technology **3+1 Processor** ▷ P. 14

The 3 + 1 parallel processing architecture addresses the heavy processing needs required by high-volume 5 million pixel-images, color processing, and advanced algorithms that perform complex numeric operations.



WIDE RANGE OF CAMERA SELECTIONS

Users can select the camera best suited for the application

Fourteen different camera types **Multi Camera System 4** ▷ P. 11

Users can select the optimum camera for their application from the industry's most extensive lineup of 5 million-pixel, 2 million-pixel, and ultra compact cameras. Each camera type is available in color or monochrome models. The CV-5000 Series can simultaneously run up to four different camera types making multi-camera applications more cost efficient.



INDUSTRY FIRST Controller-based illumination control

Introducing an expandable controller architecture **eXpandable CONTROLLER** ▷ P. 13

This architecture allows users to increase the flexibility of their systems using expansion units, which includes the camera expansion unit and the light control expansion unit. By limiting the functionality to the essentials, users can meet their requirements, reduce costs, and still maintain the flexibility to upgrade in the future.

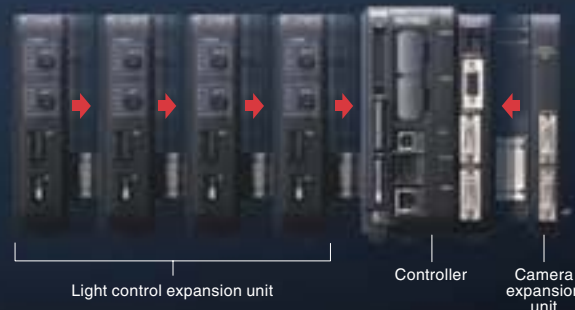



BEST IN ITS CLASS Solutions for sophisticated defect inspection applications

New defect detection algorithms for tackling difficult applications ▷ P. 16

Several new algorithms have been added to detect foreign objects or burrs on irregularly shaped profiles. These new algorithms also filter out glare or other background noise so that only the flaws are emphasized.

Applications previously considered difficult



Detection of minute flaws along the profile

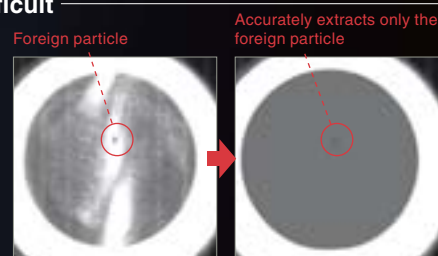

Particle detection on backgrounds with glare and other shade variations

BEST IN ITS CLASS Reliable detection under poor conditions

New image enhancement processing ▷ P. 15, 17

Significant advances were made to preprocessing functions that eliminate conditional changes caused by workpiece variation. The newly equipped Fine Color Processing function directly processes full-color information to reliably extract defects from backgrounds with pattern or illumination variations.



Foreign particle detection on a rounded metal surface

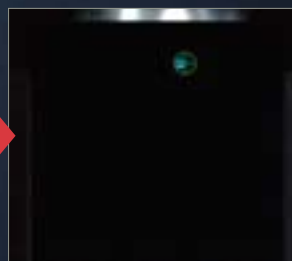

Isolates the foreign particles by cancelling out the metal reflections



Foreign particle detection on diagonal striped background



Removes the striped pattern and reveals only the foreign particle

BEST IN ITS CLASS

Full range of statistical and image archive functions ▷ P. 23

CV-5000 Series controllers come with built-in statistical functions that let the user view the inspection results in real-time. The on-board image archive can store up to 1024 past inspection images that can be reviewed at a later time. Combining these two features allows for detailed analysis of product result trends and failure conditions, making it easier than ever for users to fine tune their program tolerance and settings to improve yield rates.

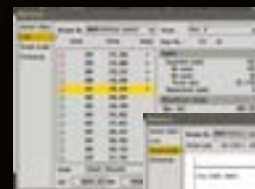

5 million-pixel, ultra high-speed cameras

[FASTEST IN THE INDUSTRY]

High-speed 5 million-pixel camera series

11x 5MEGA DIGITAL

Color type
CV-H500C

Monochrome type
CV-H500M



KEYENCE 11x high-speed cameras transfer 2432 x 2050 pixels in just 61.2 ms. This high-speed transfer rate delivers the benefits of high-definition image processing to high-throughput production lines. Now previously impossible inspections can be performed with a single camera. For example, it is possible to detect extremely minute defects on standard sized parts, or larger parts can be captured and inspected in detail with a single camera. In addition, the camera size is unobtrusive, making it easy to mount almost anywhere.

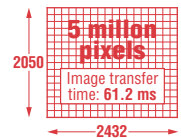

Reliably detect micro defects

Pattern breaks in solar battery electrodes

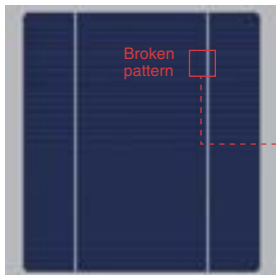

■ 310,000 pixels
Lines are out of focus and cannot be detected.

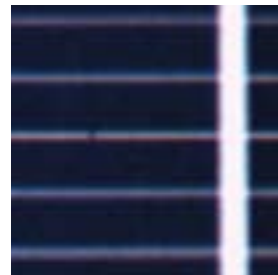

■ 2 million pixels
Broken pattern is out of focus and lacks clarity for an accurate inspection. The image requires a smaller field of view.

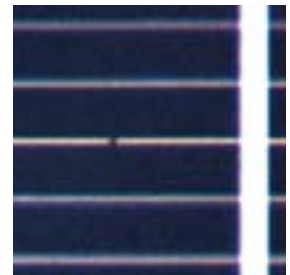

■ 5 million pixels
Lines appear sharp and the break can be accurately detected.

Capture the entire image in one shot with a wider field of view

Field of view comparisons with existing cameras

A 5 million-pixel camera can inspect the entire image at once while maintaining the resolution needed for inspection.

■ 20 million-pixel simultaneous process

Process up to 20 million pixels by connecting four 5 million-pixel cameras. All four cameras capture and transfer simultaneously.

To maintain the resolution needed for print inspections...

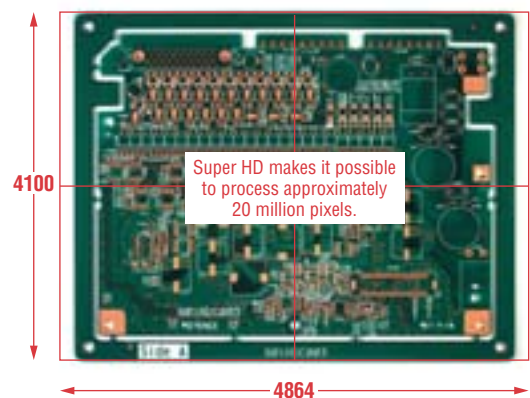
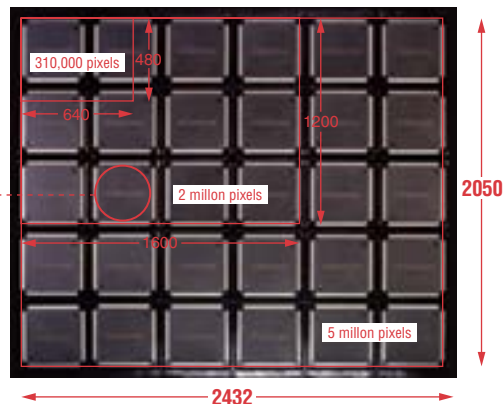

Extensive Camera Lineup

[WIDE RANGE OF CAMERA SELECTIONS] Select the camera best suited for the application

The CV-5000 Series has a vast array of camera options to allow the user to carefully select the optimum camera based on their application needs. Whether the application calls for high precision color measurement with a 5 megapixel camera, ultra-fast processing with a 7x high speed camera, or mounting within a compact enclosure, the CV-5000 Series camera lineup can provide a solution.

7x high-speed cameras

The 7x CCD cameras of the CV-5000 Series are the fastest in their class, easily supporting high-speed lines and continuously moving targets. Images can be rapidly transferred without compression, solving inspection applications previously impossible with machine vision equipment. The 2 million-pixel camera models can complete processing in about the same amount of time as conventional 310,000-pixel models, enabling high-resolution inspection without reducing product cycle times.

[FASTEST IN ITS CLASS] ■ 2 million-pixel cameras NEW

For inspections that demand both high-resolution and high-speed processing.

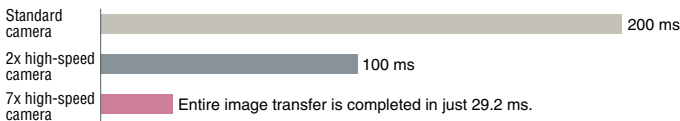

[FASTEST IN ITS CLASS] ■ 310,000-pixel cameras

For applications with priority on processing time. Transfers 640 x 480 pixels in 4.7 ms.

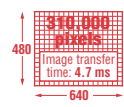
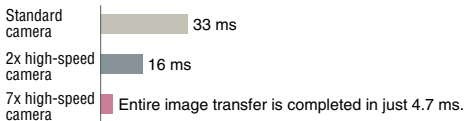

2x high-speed cameras

■ 2 million-pixel cameras

Driven by a 2 million-pixel color CCD, these cameras transfer all 2 million pixels in 59 ms. Each model is highly effective for minute defect inspections, or dimension measurements that demand high-resolution.

Color type
CV-200C
Monochrome type
CV-200M

MEGA DIGITAL



■ 310,000-pixel cameras

The 310,000-pixel cameras use a 2x high-speed progressive-drive CCD to enable transfer of 640 x 480 pixels (310,000 pixels) in 16 ms, supporting a wide range of applications.

Color type
CV-035C
Monochrome type
CV-035M

HI-SPEED DIGITAL



[SMALLEST IN THE INDUSTRY] ■ Ultra-compact cameras

Compact cameras with the same high performance as other CV-5000 Series cameras. Their small size enables installation in tight spaces normally reserved for photoelectric sensors. A 12-mm (0.47") wide, 310,000-pixel type and the industry's smallest 17-mm (0.67") wide, 2 million-pixel type are available. Different resolutions can be selected for different detection tasks. Side view attachments are also available.



Size comparison with a conventional model (CV-S035C)

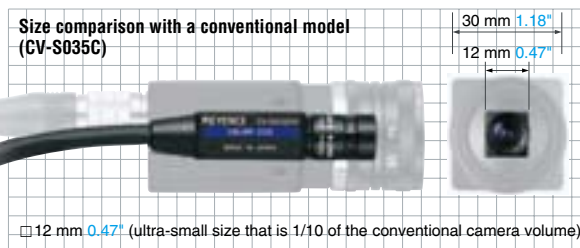

2 million-pixel color type **CV-S200C** 2 million-pixel monochrome type **CV-S200M** 310,000-pixel color type **CV-S035C** 310,000-pixel monochrome type **CV-S035M**



[INDUSTRY FIRST]



Simultaneous Acquisition Multi-Camera System

The CV-5000 Series allows simultaneous use of several different cameras selectable from a lineup of 14 different models. Users can select and combine the cameras best suited to the detection task, such as using a monochrome camera on camera 1 and a color camera on camera 2. Up to four cameras can be connected by adding the camera expansion unit.* The system runs all four cameras simultaneously (acquisition and processing), including the data-intensive 5 million-pixel color camera. The multi-camera system provides users with a flexible upgrade path to cope with future additions or changes in their inspection needs.

* The camera expansion unit can be connected to the CV-5702 and CV-5502.

[Multi-camera system]

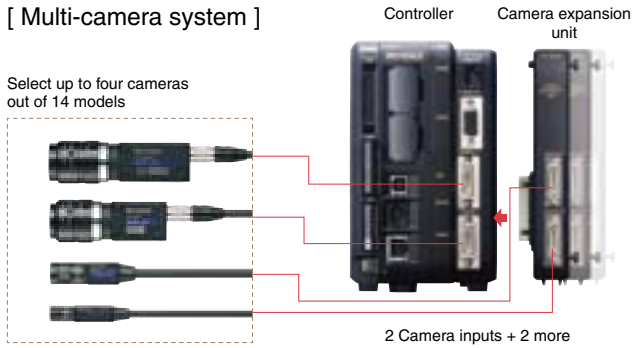

Combination examples

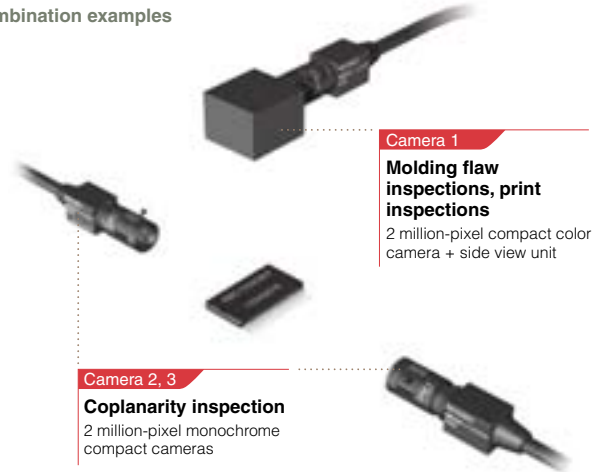

When using multiple cameras to inspect simultaneously, the ability to select cameras best suited for the inspection provides cost efficiencies for the overall system.

[NEW] EtherNet/IP capable

It is possible to input/output values and controls by using the Ethernet port.

- ▮ Communication available via implicit and explicit messaging.
- ▮ Up to 128 connected devices
- ▮ Meets Conformance Test A5 standards

Built-in Ethernet Port

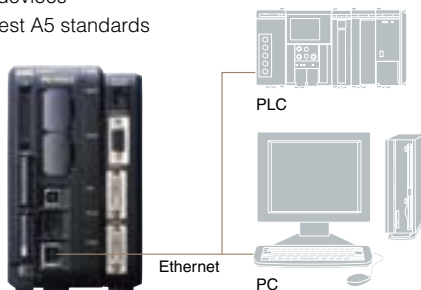

Partial image scanning

The Partial Image Scanning function significantly reduces image transfer time by transferring only the selected area of an image.

Image transfer time comparison: For the CV-H035C



Gain adjustments help increase contrast

The CV-5000 Series controllers are equipped with a camera gain adjustment feature that allows up to 81 levels of sensitivity. When capturing images using high shutter speeds, an increased gain provides more light for brighter images without the need for costly strobe light equipment. Applying span offset processing, which also supports individual adjustments for the R, G, and B components of CCD data sampled at 10 bits, the shade difference in low contrast images is expanded and reliable image processing is possible.

Effects of increased sensitivity



Image comparison at a shutter speed of 1/10,000 sec. (both images shot under the same conditions using fluorescent lighting.)

Effects of span shifting

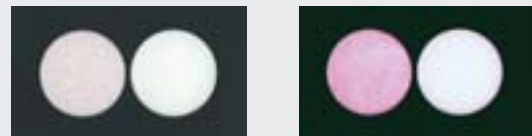

(Changed the span of the R component)

Multi-image acquisition mode

This mode consecutively acquires and processes images using only a single trigger input. The data is averaged to provide consistent results for images that appear out of focus either due to the condition of the workpiece, or variation caused by vibration in the production line. A useful feature of this mode is the Exclusion function (patent pending) that removes false measurement data. (* The maximum and minimum values of the results after processing multiple images can also be output.)

[Processing method of the Multi-image acquisition mode]

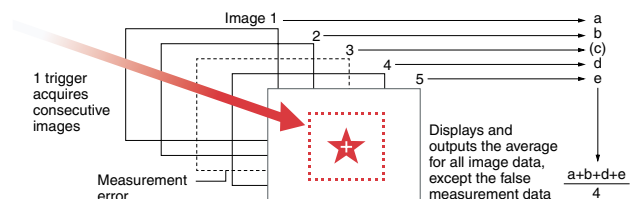

New controller architecture achieves unparalleled functionality

Enhanced specifications at an efficient cost

[**WORLD'S FIRST**]



“Expandable” controller architecture

The new CV-5000 Series offers two expansion units as add-ons to the main controller: a camera expansion unit and a light control expansion unit. This architecture allows users to control costs by selecting only units which are necessary without losing the flexibility to adapt to future changes.

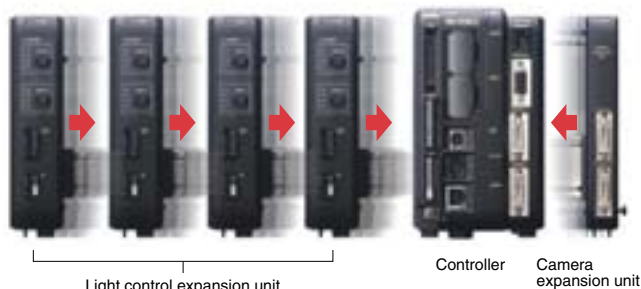

Easily control lighting without extra wiring

[**WORLD'S FIRST**]

LED light control expansion unit

Each light control expansion unit is equipped with two light terminals. The CV-5000 can control up to 4 expansion units allowing for a total of 8 lamps* to be utilized simultaneously. The controller's camera configuration menu has built-in dimmer controls and configurable lighting patterns. This provides users with complete control of illumination without separate wiring and PLC-based programming. For example, it is possible to set a lamp to strobe with each trigger input, thus extending the life of the lamp. Light intensity can also be altered through the CV user interface and external command controls.



* As long as the total power consumption of the lamps does not exceed the rated power capacity, additional lamps can be connected by using the optional splitter cable. For example, the user can connect up to sixteen 10 W lamps.

Application examples using the light control expansion unit

Lamp switching (multi-pattern lighting)

Simultaneous printing, dimensional, and orientation inspections

Low angle lighting is used for printing and dimensional inspections, while coaxial lighting is used to detect orientation. Each trigger input automatically switches between the lamps to perform all the inspections without using a PLC. Each setting can be programmed with up to four lighting patterns.

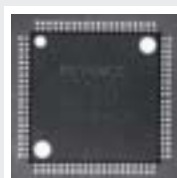

Coaxial lighting enhances the visibility of the orientation marks in the corners.



Low angle lighting enhances the printing and leads.

Light intensity presets for each program number

Automatic light intensity adjustment based on product

If the color and reflection ratios change based on the type of product being inspected, and if the product moves continuously without stopping, there may be no opportunity to adjust the light intensity without affecting the brightness of the acquired image. In this case, the desired light intensity level for each program number can be set so that it automatically changes based on the specific target properties. This will allow for uninterrupted changeovers without the need for manual adjustment.

Light Intensity: 127



For products with low reflection ratios, light intensity is a key.

Without changing the light intensity



Light Intensity: 127

Color appears saturated on parts with high reflection ratio.

Product Changeover



Light Intensity: 80

By presetting the optimum light intensity for this product, the changeover is easily completed.

No controls or wiring necessary

Product changeovers often require an adjustment in the light intensity to match the reflection properties of the product. Conventionally, this was done by a PLC which would change the light intensity settings on the light controller during product changeovers. However, with the CA-DC20E, it is possible to preset and register the appropriate light intensity for each inspection in the controller, without any extra wiring or complicated controls.

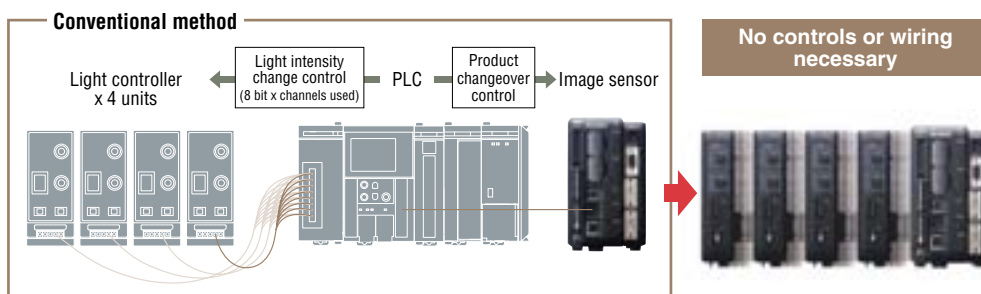

Fastest processing platform in the industry

3 + 1 Processor System: Ultra high-speed, parallel processing



CV-5000 Series models are driven by a high-speed color image processing engine (A.C.E. II). In addition, the high-speed RISC (Reduced Instruction Set Computer) CPU is supplemented by two DSP's (Digital Signal Processors) designed specifically for image processing. CV-5000 Series models use these four processors to attain the fastest processing speed available in the industry. The CPU and DSP's are the latest technology, achieving twice the speed of the KEYENCE CV-3000 Series models.



Comparison of processing by CV-5000 Series models and previous models

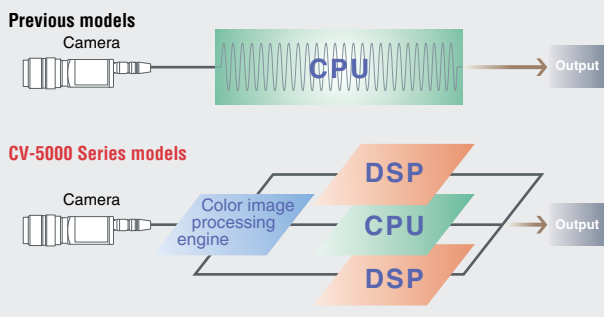

CV-5000 Series models share image processing tasks among multiple processors to achieve higher processing speeds.

■ Comparing the “3 + 1” processing system to a single CPU

The greater the image processing load (*), the more apparent the difference between the 3 + 1 parallel processing system and a single CPU system becomes. The 3 + 1 processing system is an example of the on-site stability concept of the CV-5000 Series. It allows users to optimize settings for stable performance in production-line environments without significantly increasing processing time.

Relation between image processing load and processing time (Example)

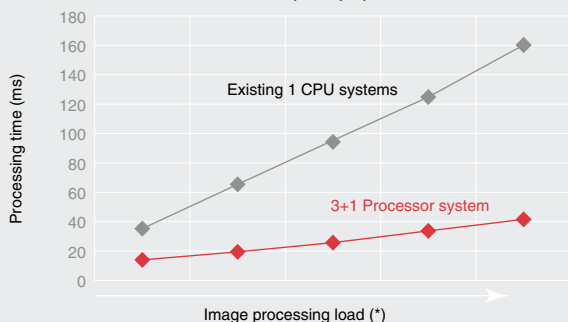

* Image processing loads

The following factors increase image processing loads:

- Detailed parameter settings for searches and stain inspections
- Adding image enhancement functions
- Increasing camera pixels
- Increasing inspection windows

■ High-speed processing examples

Chip component surface inspection

A CV-5000 Series model* completes processing with a 3-ms trigger interval.

Processing tasks

Using a 240 line partial image, the CV-5000 Series performs position compensation and color intensity processing while inspecting for defects, edge pitch, edge angle, and edge width.



Product cap surface inspection

A CV-5000 Series model* completes processing with a 12-ms trigger interval.

Processing tasks

The 7x high-speed 310,000-pixel color camera captures full-screen images and carries out several product assessments. Defect inspection, difference processing (Pattern cancelling) color intensity processing, 360° rotary position compensation, and edge position compensation provide the most comprehensive and accurate inspection of products available.



* CV-5500 combined with a CV-H035C

Double buffers

The CV-5000 Series models are equipped with double-buffered memory, allowing the unit to be triggered while processing the previous image. This allows for inspection times of 5.2 ms (approximately 11,500 images/minute) for full-screen image acquisition.

(* Assuming a 4-ms image processing time using the CV-H035C)

Existing method

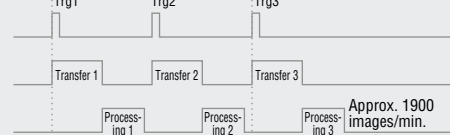

Double buffered CV-5000 Series

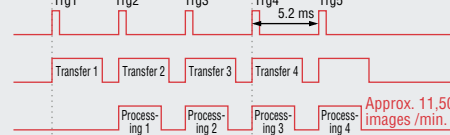

Fan-less design

In spite of the ultra high-speed processing, the CV-5000 Series models feature a fan-less design based on heat dissipation technology. A fan is a service-life component, and not using one translates into longer hours of reliable continuous operation. In addition, this design is particle emission-free, making the CV-5000 Series suitable for clean-room environments.

New color processing highlights difficult to see defects

[NEW]



New color extraction engine, A.C.E.II

The CV-5000 Series models are equipped with a new color extraction engine. The A.C.E.II (Advanced Color extraction Engine II) uses the HSB color model (closest color model to the human sensory system) to attain high color extraction performance that stabilizes previously unstable color processing schemes. CV-5000 Series models also feature "fine color processing" to extract color information exactly the way the camera captures it. This technology significantly broadens the range of color processing applications previously accomplished by machine vision systems.

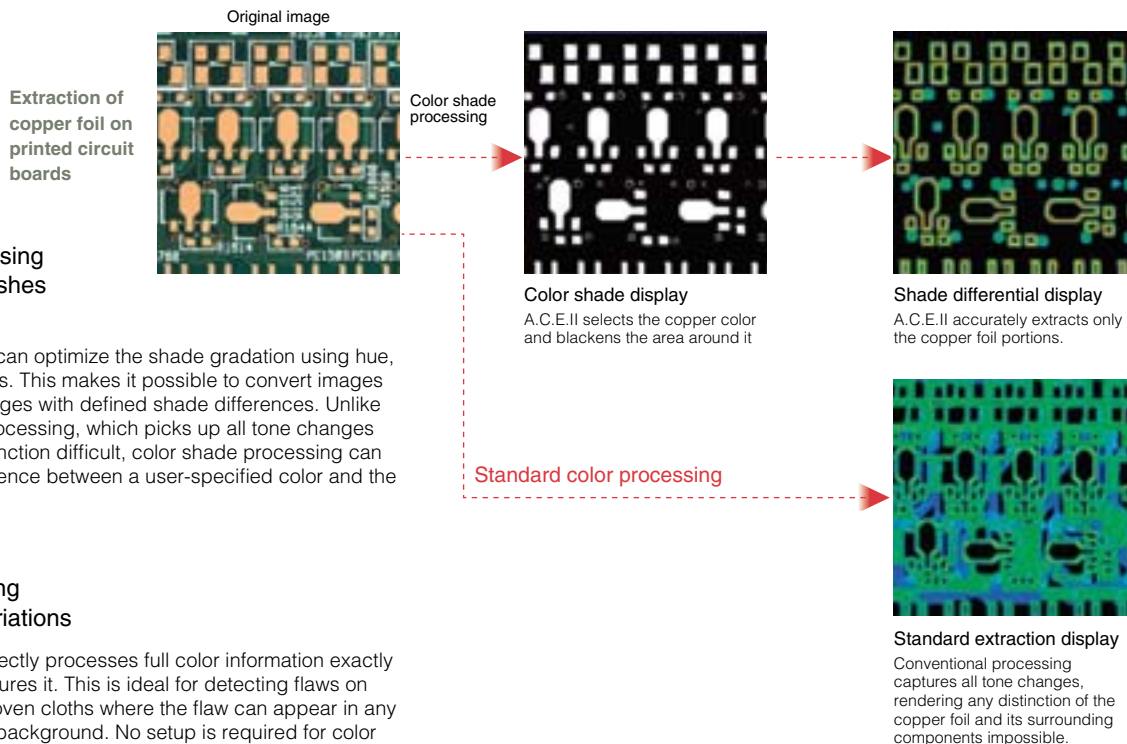

■ Color shade processing accurately distinguishes a specific color

Color shade processing can optimize the shade gradation using hue, saturation, and brightness. This makes it possible to convert images with low contrast into images with defined shade differences. Unlike conventional full color processing, which picks up all tone changes and makes pass/fail distinction difficult, color shade processing can optimize the shade difference between a user-specified color and the background.

■ Fine color processing Detects all color variations

Fine color processing directly processes full color information exactly as the color camera captures it. This is ideal for detecting flaws on sheets, films, and non-woven cloths where the flaw can appear in any color with respect to the background. No setup is required for color extraction, allowing users to complete the inspection with one simple operation.

Foreign particle detection on a non-woven cloth

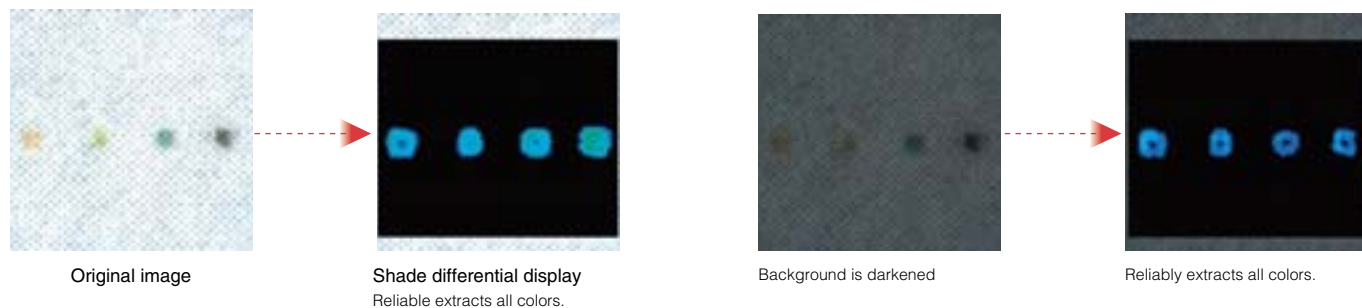

■ Glare removal

The newly added Intensity Cancellation function solves a common problem of detecting changes when using full color processing on color images. This function delivers stable detection performance to field applications by ignoring glare and lighting variations on the target background, and detecting only the area where hue and saturation differences exist.

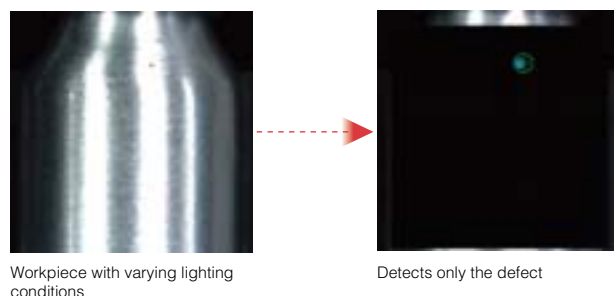

Surface defect detection

KEYENCE Machine Vision Systems has continually evolved by providing reliable solutions to inspection challenges. We have devoted countless hours of research and development to provide inspection solutions that represent the most demanding requirements. The CV-5000 Series models are equipped with advanced defect detection algorithms that eliminate many of the instabilities normally associated with surface appearance inspections.

Isolates defects for detection on shaded backgrounds

[FIRST IN ITS CLASS] Real-time shade correction (patent pending)

Real-time shade correction isolates defects, even when the background has shadow-like gradations. This filter enables inspections not possible before by cancelling shadows that even lighting techniques could not remove. Unlike commonly used shading correction filters that apply the same correction to all images, this correction adapts in real time to constantly changing shades.

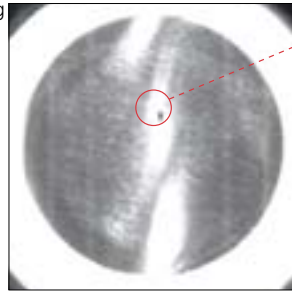

Original image
Inspections are difficult due to inconsistent glare on each workpiece.

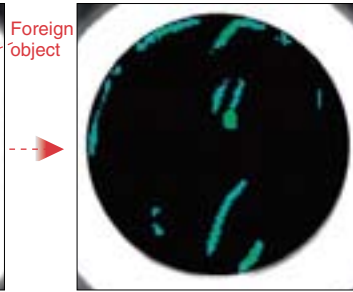

Conventional method (no real-time shade correction, stain mode stability display)
Erroneously detects areas of glare as defects.

Accurately extracts only the foreign object

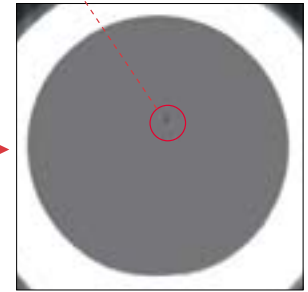

Real-time shade correction
Shaded areas on the background are cancelled, revealing only the foreign object. Repeatedly extracts only the foreign object, even if the glare has a different shape for each image.

Application Example: Surface inspection of curved surfaces on metal



Normally, the dent in this image could not be detected because of the random glare and granular texture of the metal.

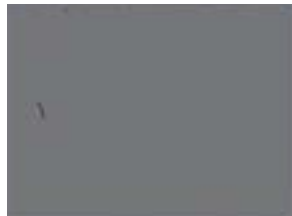

The image enhancement filter extracts only the dent.



The same workpiece with a line-like scratch.



Cancels glare and isolates the scratch.

Powerful features for detecting burrs or flaws on profiles

[FIRST IN ITS CLASS] Trend Edge Defect Detection (patent pending)

This tool extracts the profile from the edge of a workpiece and uses it to recognize large differences such as burrs or flaws. In addition to geometrical shapes such as circles and straight lines, the tool also recognizes complex contours, such as ovals and free-form curves.

Detecting burrs and flaws in resin molded parts

Profile trace image

Trend edge detects the profile of the workpiece and automatically generates reference model lines (the green line in this image) consisting of free-form curves.

Original image



Burr detection



The burr generates a difference in the distance from the reference line, which allows the tool to detect it.

Flaw detection

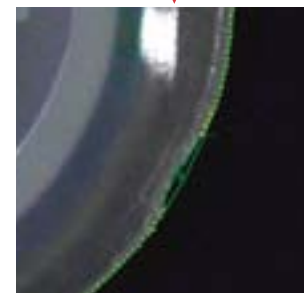

The tool reliably detects even the most subtle nicks along the profile, a defect otherwise considered difficult to detect.

Powerful defect extraction using original algorithms

[MOST EXTENSIVE AND POWERFUL IN ITS CLASS] Image Enhancement Preprocessing Filters

The CV-5000 Series features 18 preprocessing filters that highlight otherwise obscure defects. Users can combine up to 13 preprocessing filters in a single window.

NEW

Softening filter (patent pending)

Softening reduces fine patterns and noise in the background. The softening effect is individually adjustable in the X and Y directions. This filter can be applied to a wide range of applications, including part counting inspections.

Detecting foreign objects on a striped pattern

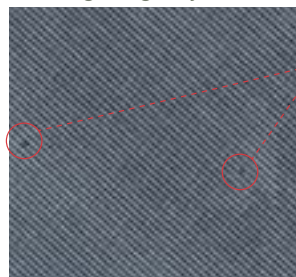

Original image
This inspection would have been impossible because of the diagonal stripe pattern.

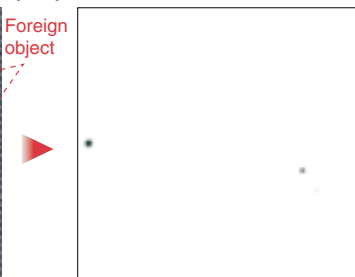

Softening filter + real-time shade correction
Striped background removed, allowing extraction of only the foreign objects.



Stain detection
Reliable detection of foreign objects.

Differential inspection

The differential process inspects defects by ignoring patterns in the background. Users can choose from two processing methods to suit the application.

Differential processing with a registered image

This method extracts only the differences found by comparing the acquired image to a preregistered master image. The level of difference that determines a defect is adjustable to account for individual part variation.

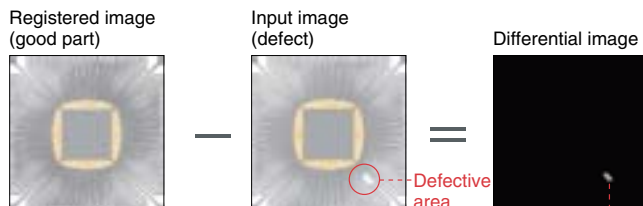

Only the defective area is extracted, even on objects with complex shapes such as leadframes.

Extracts only the defective area

Real-time differential processing

This method analyzes acquired images in real time. The process ignores the background and searches for minute variations within the image, without using a master image.

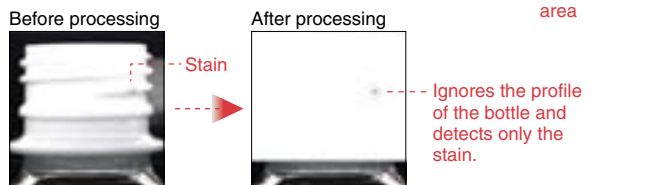

Ignores the profile of the bottle and detects only the stain.

Inspecting bottle openings

Reliably captures burrs and flaws along distorted circles and free-formed lines.

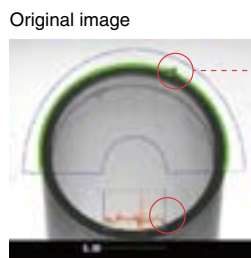

Original image

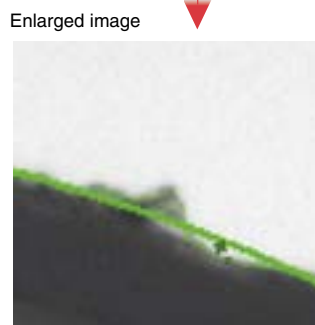

Enlarged image

Stable detection, even when the camera is mounted at an angle.

Introducing the newest standard in surface inspection [MOST POWERFUL IN ITS CLASS] Stain inspection tool

The Stain inspection tool searches for scratches and stains by comparing them against the surrounding shade level. Compared to binary processing, this mode has greater tolerance against varying conditions, making it ideal for surface inspections on production lines where individual variation of parts and light intensity fluctuations otherwise present problems. The defect distribution display allows optimized tuning by providing a quick visualization of how the image processor sees the defect.

Defect Distribution Display [patent pending]

Using the colors blue, green, yellow, and red, the defect distribution display assigns a color to defects according to the intensity difference between it and the surrounding area. This provides a visual understanding of the difference between intended and unintended defect regions.

Relation between stability display color and stain level (guideline)

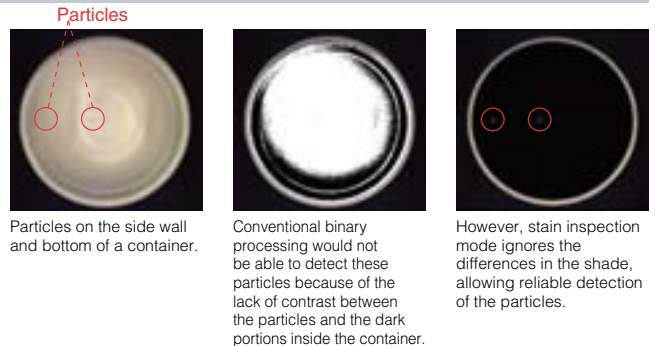

Bad mark detection on PCBs

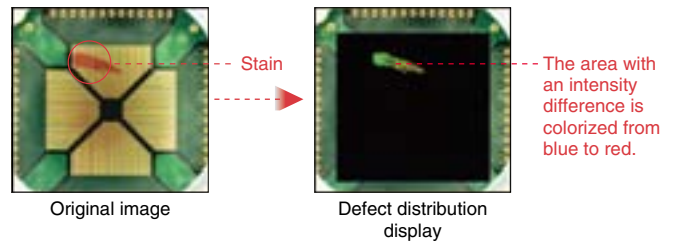

The defect distribution display appears in real-time so that users can intuitively maximize the difference between intended and unintended areas of inspection.

The algorithm of the stain inspection tool equipped on the KEYENCE CV Series.

Stain extraction method

① The stain inspection tool measures the average intensity of specified areas (segments) and then shifts by 1/4 the area of the segment size.

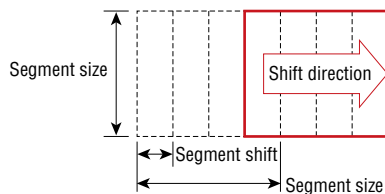

② It determines the difference between maximum and minimum intensity of 4 segments, including a standard segment (①95 in the figure below). The difference is considered the stain level of a standard segment.

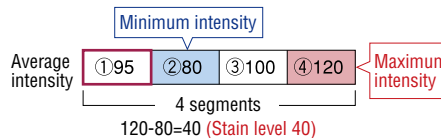

③ When the stain level exceeds the preset threshold, the standard segment is counted as a stain. The number of times the preset threshold is exceeded in a measured area is called the "Stain Area".

It repeats ① to ③ constantly shifting the standard segment within the measured area.

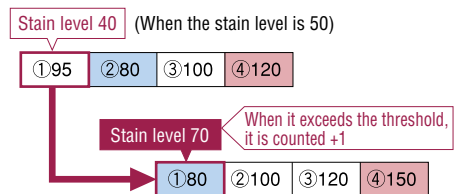

When X and Y directions are specified as the detection direction

The difference between the maximum and minimum intensity of 16 segments in both the X and Y directions are calculated using the standard segment as a reference.

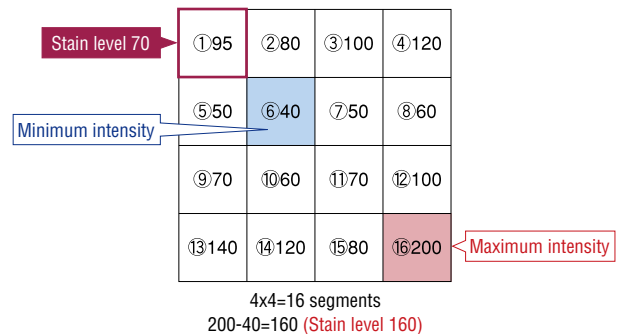

Measurement Solutions

Measure profiles using only a single inspection tool

[MOST POWERFUL IN ITS CLASS] Trend Edge Function (patent pending)

The Trend Edge tool detects edges at user-specified distances within the inspection area, and outputs the max, min, and average of all the data from each measured point. Previously, this required multiple windows and calculation settings, but now the same inspection can be done by configuring a single inspection setting. The measurements obtained can also be used to draw approximated lines and virtual circles.

Inspection theory

Trend edge detects the width and position of edges while moving across narrow segments at fine pitches.

- To increase position detection accuracy
--- make the segment size smaller.
- To reduce processing time
--- increases the shifting width (travel distance) within the segment.
- Trend direction refers to
--- the direction to move within the segment.

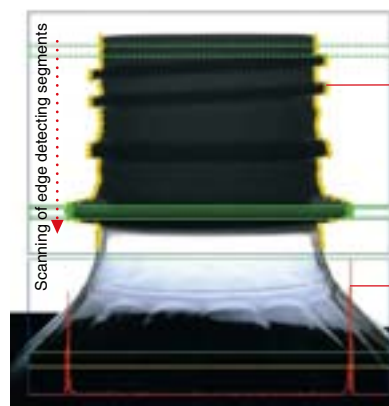
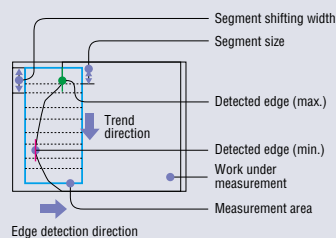

Displays detected edge position and outputs the individual results.

Provides edge intensity waveforms for each segment.

Detects the edge width and edge position of each point while moving narrow segments in fine pitches.

■ Circle Detection function

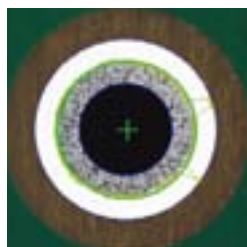

Detecting through-hole centers

Trend edge can calculate the center and diameter of a hole by drawing a virtual circle along multiple edge positions around a through hole. Abnormal edge positions are removed before drawing the virtual circle to allow for reliable measurements.

■ Line Detection function

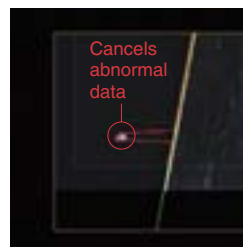

Detecting the position of glass substrate edges

Trend edge can draw a virtual straight line along edge positions of a substrate's edge. As with the circle detection, line detection also cancels abnormal edge positions.

Measure a variety of geometric shapes

[MOST EXTENSIVE IN ITS CLASS] Geometric dimensional measurement

CV-5000 Series models can measure a variety of geometric dimensions based on position data obtained through edge detection and pattern searches.

Measurable items

- 2-point distance • Angle of line between 2 points • Circle radius • Circle center
- Average angle • Lines • Intersections • Point-to-line distance • Line angle
- 2-line intersection • Perpendicular line between points and lines • Bisect
- Middle point



Dimensional measurement of a molded part

Measures concentricity and angles formed by lines through the centers of the large and small holes.

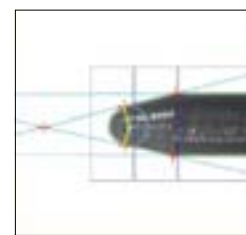

Dimensional measurement of a metal part

Measures tip radius, angle, and outer diameter.

Measure dimensions with even greater accuracy by using a 5 megapixel camera.

Assuming a 50-mm 1.97" field of view in the X axis -> approx. repeatability accuracy $\pm 1 \mu\text{m} \pm 0.04 \text{ Mil}$ (Typical example, FOV of 50 mm 1.97" $\approx 2430 \text{ pixels} \times \pm 0.5 \text{ pixels}$ (repeatability accuracy) $\approx \pm 1 \mu\text{m} \pm 0.04 \text{ Mil}$)

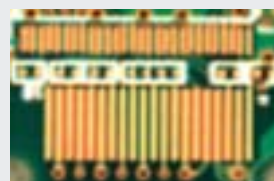

Enlarged image using a 310,000-pixel camera

Enlarged image causes blurry edges, rendering the target unsuitable for precision measurements.

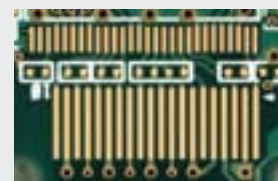

Enlarged image using a 5,000,000-pixel camera

Profiles in the object are crisp allowing precision measurements.

Character Recognition

OCR Function

CV-5000 Series models are OCR capable. Simply register the characters and specify the area of inspection. OCR supports alphanumeric, user-defined characters, and also features an automatic calendar for date and lot number inspection without daily registering or setting changes.

Printing inspection for consumption dates

Automatically extracts one character at a time to recognize characters.



Automatic calendar support

Provides functionality of dedicated OCR devices such as offsetting, tolerance adjustment, and zero-suppressing.

Selectable extraction method

Allows selection between automatic or fixed extraction. Automatic extraction also features a user-specified extraction ratio.

NEW Date encryption support

Recognizes and determines pass/fail of encrypted dates by converting characters according to an encryption table.

Recognition level reporting

Outputs character recognition level per character for quick identification of print quality problems.

Batch library registration screen



Allows registration of 20 user-defined characters (symbols, etc.), in addition to standard alphanumeric characters.

Effortless registration simultaneously saves characters in the program library.

Examples of reliable detection by using preprocessing filters

The differential filter and color shade processing can be used to isolate the background from the printing. This allows reliable inspection even when the background changes.

Original image



After processing (real-time differential)



Cancel background to isolate printing.

Other Inspection Tools

Wide array of inspection tools (Eighteen tools)

CV-5000 Series models have a wide array of inspection tools to provide solutions to almost any inspection. These tools enable users to select the optimum inspection method, including the ability to set simultaneous inspections for a single trigger input.

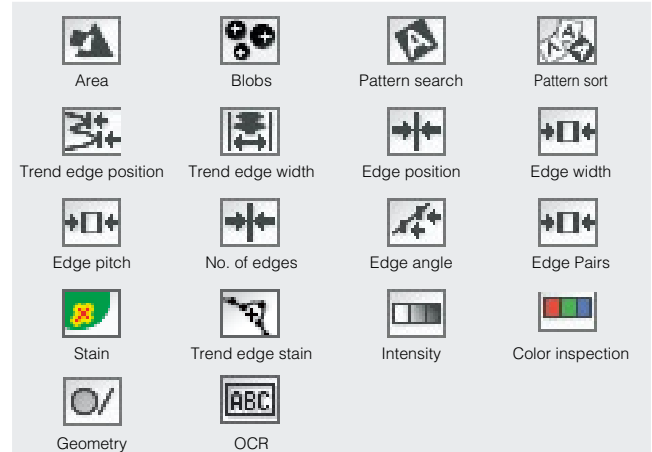

Typical inspection tools

Color inspection

Distinguishes colors by digitizing hue, saturation, and brightness for greater color-detection accuracy. Unlike conventional color detection where color is distinguished by the size of the extracted area of color, the CV-5000 Series models actually reference the digital value.

LED lighting inspection

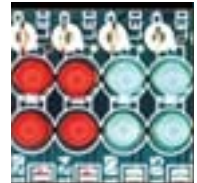

Part count

Counts parts by using the blob tool allowing inspection of the center point, perimeter length, and circularity of each part found.

Counting terminals



Other Features

Conditional branching

Each inspection window can be configured to execute based on the results of another window or numeric operation.

Command memory

Features memory for 1,000 commands. The memory is programmable during operation by an external input or the console, and can be referenced by numerical operations.

Auto-adjusting inspection areas

Inspection areas (rectangles, circles) can be created in real-time with edge position detection or numeric operations.

Scaling

Pixels can be scaled to the dimensions of the field of view.

Individual triggers, strobe light support

Individual trigger input allows sequential image acquisition using multiple cameras. Individual strobe outputs are also supported.

Compatibility with CV-3000 Series settings

Setting files for our CV-3000 Series are upward-compatible.

Reliable and Easy On-Site Operation

Reduces light disturbances for highly reliable inspections

Automatically corrects for variations in light intensity in order to provide consistent illumination.

By saving a reference image acquired under optimal lighting conditions, the controller can monitor the light intensity each time it acquires and processes an image. An automatic digital gain adjustment corrects the light intensity to match the original reference image for less measurement variation over the life of the light source.

Reference image



The light intensity of this image becomes the reference. By registering it before the inspection, the controller can correct the light intensity for images that deviate from this reference by a given amount.

Acquired image



The acquired image before correction.

Corrected image



Based on the difference in light intensity detected in the acquired image compared to the registered reference image, the controller corrects the light intensity within the inspection area.

[BEST IN ITS CLASS]

Wide array of image enhancement filters

CV-5000 Series controllers are loaded with a wide array of filters to remove noise and isolate or otherwise enhance detection areas. In addition to the Expansion, Shrink, and Sobel filters, a total of 18 filters can be used, including preprocessing filters for binary color conversion and color shade processing.

Original image



Shrink



Sobel



Real-time differential

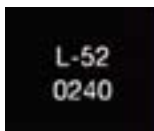

Apply 13 layers out of 18 available filters in any combination.

KEYENCE Vision Flow menu

KEYENCE has further improved its vision flow menu to ensure a user-friendly setup. This intuitive menu flows from top to bottom, guiding users through the simple setup procedures.

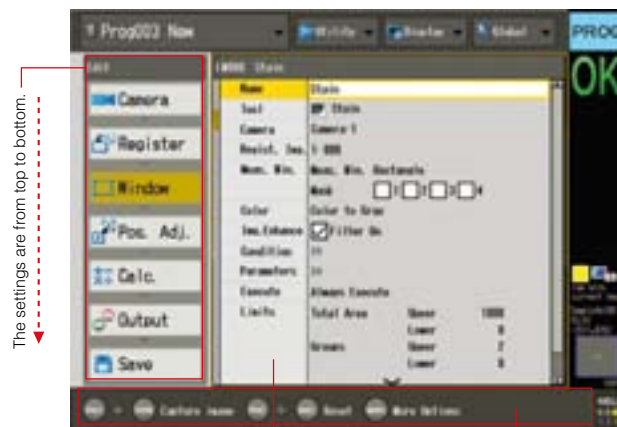

The settings are from top to bottom.

Preview display enables the user to understand window settings at a glance.

Help display assists in key operations.

Zoom Display function

The Zoom Display function enables users to continuously zoom the display screen from 0.04 times to 25 times. This function can be used regardless of the operation status or programming menu.

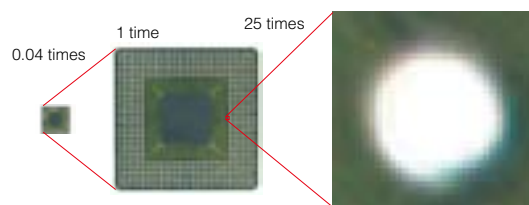

Other functions

Image capturing

Allows on-demand image capturing to the removable SD memory card (bitmap format).

File management

Allows users to copy files on the SD card or format a new card without using a PC.

I/O communication monitor

Displays the I/O signal status during setup and operation.

Operator-friendly display options

SVGA monitor output

KEYENCE has adopted a high-resolution SVGA (800 x 600 pixels) monitor output for superior image quality. This function enables the user to quickly monitor the operational status of the inspection at an extensive level. Multiple inspection images can be monitored simultaneously, eliminating the need to switch the screens on the remote console.

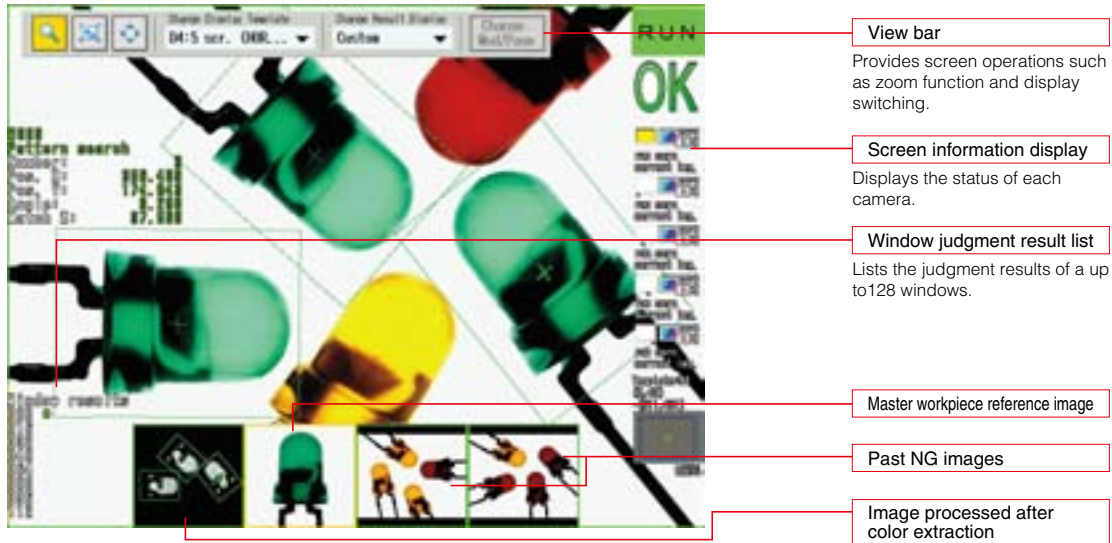

Selectable screen display formats NEW

Choose from nine available screen display formats to match the user's application needs. Display cameras and display contents can be chosen per screen, making it possible to view current images on the main screen while viewing past NG images and registered images on subscreens.



Display of one screen



Display of two screens



Display of four screens



Display of five screens

Custom Display function NEW

The Custom Display function enables flexible creation of user-defined displays such as the judgment results or measured values of only specified inspection windows. With this function, the user can also create and display custom text and graphics.



Example of custom display

Administrator mode/operator mode (password enabled)

The administrator mode/operator mode enables management of operational changes with the use of passwords. This prevents unauthorized changes to the system. Combining this function with the custom menu permits only specific functions to be accessed in operator mode.

Custom menu NEW

The custom menu displays only necessary menu items. For example, the normal menu view can be reduced to only display settings for color extraction and limit setup. This will help to simplify programming and prevent unauthorized system tampering.



In the past, it was possible to alter all the items in setting menus. For this reason, there was a risk that unauthorized users might alter items mistakenly.



After the display menu is customized, only the items required for daily operation are displayed, so operators can easily understand the settings. This reduces the risk that operators will perform an incorrect operation.

Powerful troubleshooting tools

Statistical processing

The Statistical function enables the user to store up to 20,000 points of measurement data in the internal memory of the unit and easily check the maximum value, minimum value, average value, standard deviation, NG count, and yield, all without having to connect to an external PC. This function also enables the user to display trend graphs and histograms and make on-the-fly changes to limits based on the results of the gathered data. Up to 1024* previously captured images can also be accessed directly on the graph. (*using the CV-035M or CV-S035M).

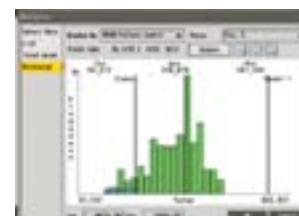
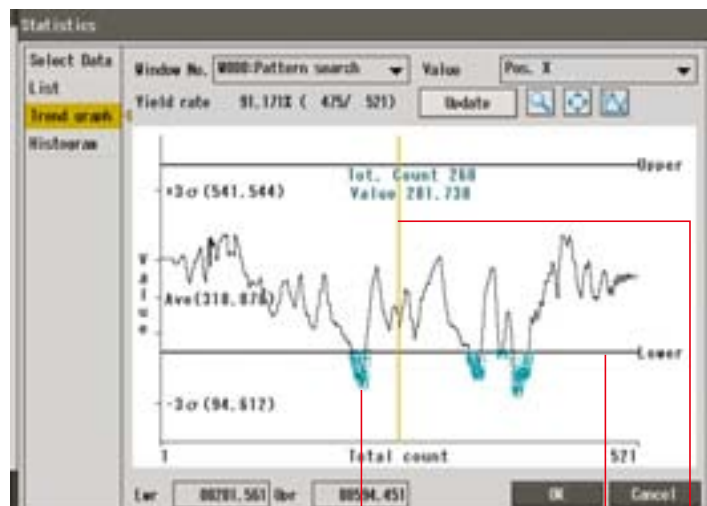

Histogram display

Measured values list screen

Trend graph display

Screen storage mark

The data with a square mark contains a saved image. Clicking this icon calls up the image.



Simultaneous display of images and measurement results.

Tolerance

Displays the upper or lower limit.

Vertical cursor

Displays the measured values of the selected data and measurement count.

[BEST IN ITS CLASS] Image Archive and Retest function

The Image Archive function saves inspected images to the internal memory or a memory card. With this function, the previously failed images can be viewed during operation. The saved images can also be retested using new settings to verify proper operation of any adjustments made to the program.

Maximum image storage capacity per camera*

Type of camera	Main unit memory	4 GB SD card
Monochrome 240,000 pixels	1,023 images	15,314 images
Color 240,000 pixels	1,020 images	5,328 images
Monochrome 310,000 pixels	511 images	12,367 images
Color 310,000 pixels	509 images	4,265 images
Monochrome 2,000,000 pixels	127 images	2,077 images
Color 2,000,000 pixels	124 images	696 images
Monochrome 5,000,000 pixels	50 images	808 images
Color 5,000,000 pixels	47 images	270 images



* For images saved to the main unit memory on the CV-5702, the number of images indicates the representative values when the number of cameras to be connected is 1 and the accumulation condition is "all". For images saved to the 4GB SD card, the number of images indicates the representative values when the number of cameras to be connected is 1.

Real time data acquisition with PC Simulator

MULTI-LINE DATA ACQUISITION

Keyence unique software packages offer simultaneous real-time data acquisition of both measurement results and captured images from up to 8 controllers. The following versions of CV-H software are available:

1. CV-H1NE – Dedicated data acquisition software for CV-2100
2. CV-H3N – Dedicated data acquisition software for CV-3002/3502 with optional PC Simulator function
3. CV-H5N – Dedicated data acquisition software for CV-5002/5502/5702 with optional PC Simulator function

Data and image collection

Measurement values collected on the CV controller can be output via RS232, Ethernet, or USB.

The acquired data can be simultaneously displayed and saved onto an external hard drive.

Captured images that are transferred to a PC can be sorted by their OK/NG status based on the measurement results. The images are then displayed in real time and saved to a specified folder.

Transfer and backup programs on a PC

Programs created on the CV controller can be easily transferred and saved on a PC. If the contents of the controller get erased, the saved files can be quickly reloaded to the vision system, reducing downtime.

If record keeping is essential, all program properties and settings can be output to an Excel* spreadsheet and saved for future reference.

Advanced Data logging

A time-based data log can be set to collect data from various shifts or product runs. Specific pieces of measurement data can also be tied to the corresponding image that was saved on the PC for easy reference.

Data can also be output to a pre-existing Excel* spreadsheet, making the CV data simple to integrate into existing reports.

*Excel is a registered trademark of Microsoft Corporation, U.S.A.

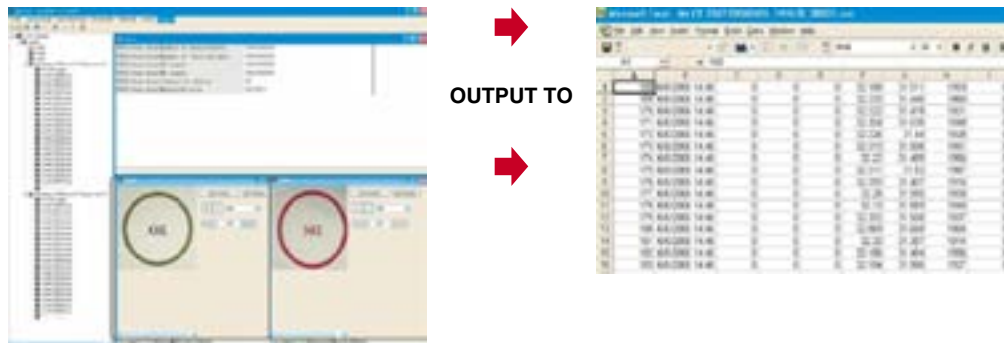

Data is both displayed and saved in real time

CV-H5N PC Simulator Function

CV SIMULATOR

Keyence has added the option of remotely programming the CV from a desktop PC. The CV-H5N PC simulator is designed to precisely mimic the operations of the CV-5002/5502/5702 machine vision controllers. All that is needed is a .bmp or .jpg image and it is ready to program!

- Choose to program/troubleshoot directly online (CV controller) or remotely (PC Simulator), providing optimal flexibility
- Transfer programs & images in real time to make remote, offline modifications to an existing CV-5000 Series controller
- Manage CV programs from anywhere in the world!

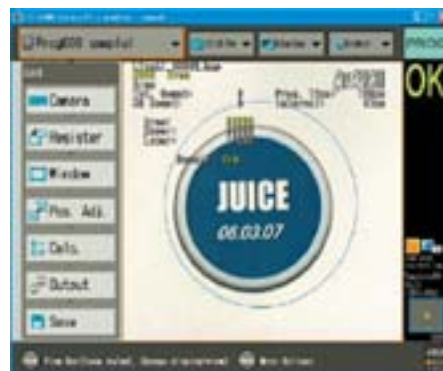

Both Software Tools in One Package
EXAMPLE OF EFFICIENT OPERATION

Operations with data collection and PC Simulator

Only one step
on-site

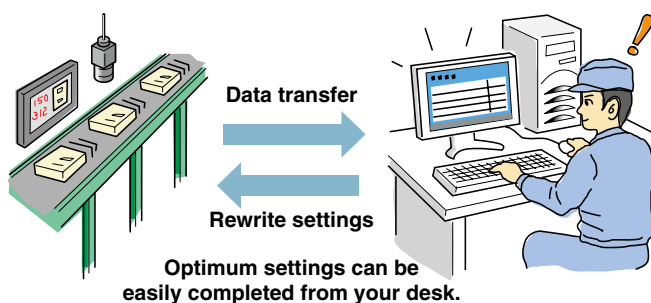
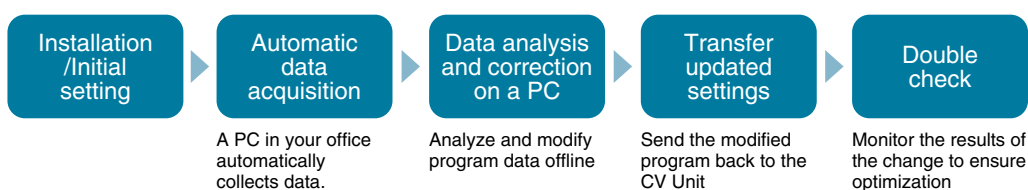

Multiple Interface Options for Seamless Integration

[FIRST IN THE INDUSTRY]

Save to mass-storage twin SD cards

First in the industry to support the SDHC standard (*). There are 2 available slots for SD cards. With a total capacity of 8GB, a large amount of configuration files and failed screen data can be saved at high speeds.



*Reading SDHC standard SD cards via a PC requires a dedicated card reader (commercially available).

USB 2.0 connector

USB 2.0 allows for quick transfer of image data and settings from your PC. No setup necessary. Ready to use on-site.

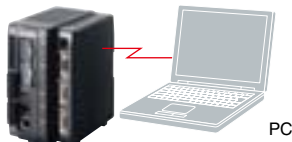

PC

Illumination control expansion unit

This connector is for the illumination control expansion unit CA-DC20E.

Expansion unit
CA-DC20E



Camera connector

The camera cable connection is recessed to minimize dead space when mounted inside control cabinets.



Camera expansion unit connector

Connects the camera expansion unit CV-E500 when 3 or 4 cameras are used.



Camera expansion unit CV-E500

RS-232C communication

Enables a PLC link with PLCs made by other manufacturers. Communicates directly with PLC data memory without additional ladder programs.

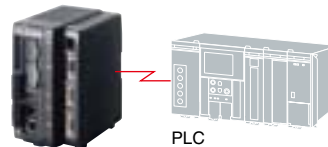

PLC

EtherNet/IP Communication

EIP communication is enabled through the Ethernet port so that data can easily be sent to Rockwell PLCs, or other EIP devices.



PC

[System configuration diagram]

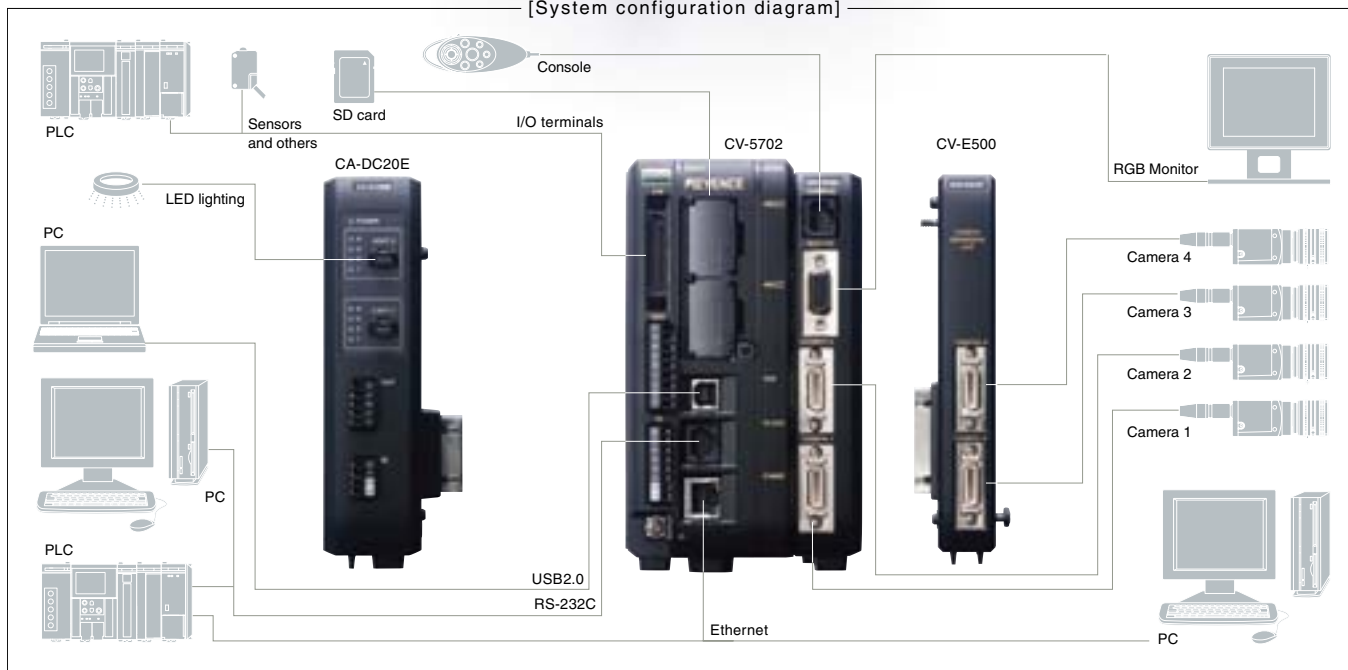

Product Lineup and Options

HISTORY
INDEX
APPLICATIONS
CV-5000 SERIES
CV-700 SERIES
ILLUMINATION
LENSES
PERIPHERALS

Controllers

High-speed, high-capacity controller with 5,000,000-pixel camera support
CV-5702(P)



High-speed, high-capacity controller
CV-5502(P)



310,000-pixel dedicated controller
CV-5002(P)



Camera expansion unit
CV-E500



LED light control expansion unit
CA-DC20E



Accessories

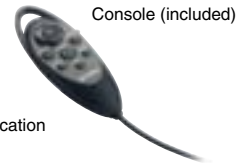

Communication software
CV-H5N



Windows XP Professional/ Home Edition, SP2 or later
Windows 2000 Professional SP4 or later
Windows Vista (Ultimate Business, Home, Premium, Home Basic)

5 megapixel cameras

11x high-speed Color camera
CV-H500C



11x high-speed Monochrome camera
CV-H5200M

7x high-speed Color camera
CV-H200C



7x high-speed Monochrome camera
CV-H200M

Color camera
CV-200C



Monochrome camera
CV-200M

Ultra-compact Color camera
CV-S200C



Ultra-compact Monochrome camera
CV-S200M

310,000 pixel cameras

7x high-speed Color camera
CV-H035C



7x high-speed Monochrome camera
CV-H035M

Color camera
CV-035C



Monochrome camera
CV-035M

Ultra-compact Color camera
CV-S035C



Ultra-compact Monochrome camera
CV-S035M

Options

Camera cable
CA-CN1 (1M 3.3') / CA-CN3 (3M 9.8') / CA-CN10 (10M 32.3') / CA-CN17* (17M 55.8')



Flex-resistance camera cable
CA-CN3R (3M 9.8') / CA-CN10R (10M 32.8') / CA-CN17R (17M 55.8')* / CA-CN7RE (7-M 23' extension cable)



L-type connector camera cable
CA-CN3L (3M 9.8') / CA-CN10L (10M 32.8') / CA-CN17L (17M 55.8')



Camera cable dedicated for high-speed cameras
CA-CH3 (3M 9.8') / CA-CH10 (10M 32.8')



L-type connector camera cable dedicated for high-speed cameras
CA-CH3L (3M 9.8') / CA-CH10L (10M 32.8')



Flex-resistance camera cable dedicated for high-speed cameras
CA-CH3R (3M 9.8') / CA-CH10R (10M 32.8')



Monitor cable
OP-66842 (3M 9.8')



RS-232C communication cable
OP-26487 (2.5M 8.2')



Ethernet cable
OP-66843 (3M 9.8')



USB cable
OP-66844 (2M 6.6')



Extension I/O cable
OP-51657 (3M 9.8')



Communication cable conversion connector
9 pins: **OP-26486**
25 pins: **OP-26485**
9 pins for SYSMAC: **OP-84384**
9 pins for MELSEC: **OP-86930**



SD card
4GB **CA-SD4G (SDHC)**
1GB **CA-SD1G**
256MB **OP-84232**



2-way split cable for LED lighting
CA-D1W (1M 3.3')



Cable for LED lighting (Loose leads)
OP-84457 (1M 3.3')



Cable for LED lighting
CA-D2 (2M 6.6')
CA-D5 (5M 16.4')

Flex-resistance cable for LED lighting
CA-D3R (3M 9.8')
CA-D5R (5M 16.4')
CA-D10R (10M 32.8')
CA-D17R (17M 55.8')

* Can only be used with 310,000 pixel cameras

Specifications

Controller

Model		NPN PNP	CV-5702 CV-5702P	CV-5502 CV-5502P	CV-5002 CV-5002P
No. of pixels	When CV-H500C and CV-H500M are connected		5,000,000-pixel mode: 2432 (H) x 2050 (V), about 4,990,000-pixels	—	—
	When CV-200C/CV-S200C/CV-H200C/CV-S200M and CV-H200M are connected		2,000,000-pixel mode: 1600 (H) x 1200 (V), about 1,920,000 pixels 1,000,000-pixel mode: 1024 (H) x 960 (V), about 980,000 pixels	2,000,000-pixel mode: 1600 (H) x 1200 (V), about 1,920,000-pixels 1,000,000-pixel mode: 1024 (H) x 960 (V), about 980,000 pixels	—
	When CV-035C/CV-S035C/CV-H035C/CV-035M/CV-S035M and CV-H035M are connected		310,000-pixel mode: 640 (H) x 480 (V), about 310,000 pixels 240,000-pixel mode: 512 (H) x 480 (V), about 240,000 pixels	310,000-pixel mode: 640 (H) x 480 (V), about 310,000 pixels 240,000-pixel mode: 512 (H) x 480 (V), about 240,000 pixels	310,000-pixel mode: 640 (H) x 480 (V), about 310,000 pixels 240,000-pixel mode: 512 (H) x 480 (V), about 240,000 pixels
Camera input			2 color/monochrome cameras (Support for CV-H500C/CV-H200C/CV-S200C/CV-035C/CV-S035C/CV-H035C/CV-H500M/CV-H200M/CV-200M/CV-S200M/CV-035M/CV-S035M and CV-H035M possible mixed connection) Connecting expansion unit CV-E500 provides 2-point expansion and connection of up to 4 points	2 color/monochrome cameras (Support for CV-H200C/CV-200C/CV-S200C/CV-035C/CV-S035C/CV-H035C/CV-H200M/CV-200M/CV-S200M/CV-035M/CV-S035M and CV-H035M possible mixed connection) Connecting expansion unit CV-E500 provides 2-point expansion and connection of up to 4 points.	2 color/monochrome cameras (Support for CV-035C/CV-S035C/CV-H035C/CV-035M/CV-S035M and CV-H035M possible mixed connection)
Main processor for image processing			DSP (high-speed type)		DSP
No. of registered settings			Up to 1000 settings, separately, for SD card 1 and SD card 2 (depends on memory card capacity and setting), supports external changover		
Number of screens that can be registered			1000 screens max./setting (depends on memory card capacity), can be compressed and saved, supports registration of position adjusted images		
Internal memory capacity			SD card slot x 2 (SDHC support) OP-84232 (256MB: Standard equipment on the SD1 slot of the CV-5502/5002), CA-SD1G (1GB: Standard equipment on the SD1 slot of the CV-5702), CA-SD4G (4GB: SDHC) support		
Window setting	Measurement area, Mask area		Measurement: 128 windows/program Mask: 4 areas/window		
	Area shape (depending on the inspection mode to be used, some area shapes are restricted)		Rectangle, rotating rectangle, circle, ellipse, ring, arc, polygon (up to 12 angles), Auto-adjusting rectangle, Auto-adjusting circle		
Color extraction function (valid only when a color camera is connected)			Color binary, color shade, grey, RGB grey (color corresponds to numeric value specification with HSB values) 1:n copy supported		
Measurement tool	Area measurement		Area (color binary, monochrome binary)		
	Position detection	Edge tool	Pattern search (support of multiple detections), pattern sort, edge position, trend edge position, blob (gravity center position)		
		Feature inspection	Edge width, edge pitch, No. of edges, edge angle, pair edge, trend edge width		
	Inspection mode	Stain/inspection	Stain detection (support of differential stain detection through combined use with the differential filter, detection of multiple positions through grouping (hole-filling enable/disable selectable), and stability display, support for directly measuring color images with fine color)		
		Sorting	Pattern sort (256 types max.)		
		Shade inspection	Shade inspection, color inspection (valid only when a color camera is connected)		
		Geometry	Display of points, lines, and circle areas where the operation result can be cited		
Character recognition		OCR (2 lines maximum, 20 characters/line) Supports date/time encryption function			
Trend edge defect	Appearance inspection using a line, circle, arc, or freeform reference model line				
Continuous capture function			1-to-32-times continuous capture processing (maximum value, minimum value, average value), possible exclusion of the measurement error from the measurement result		
Execution condition setting function			Enables you to set execution or non-execution that works with the measurement judgment results (OK/NG) of other optional windows per measurement window.		
Image capturing setting function	Processing area setting function		Enables you to specify a 980,000-pixel area (1024 (H) x 960 (V)) in any position as the processing area within 1,920,000 pixels (1,000,000-pixel mode). Enables you to specify a 240,000-pixel area (512 (H) x 480 (V)) or 310,000-pixel area (640(H) x 480 (V)) in any position as the processing area within 320,000 pixels.*1	Enables you to specify a 240,000-pixel area (512 (H) x 480 (V)) or 310,000-pixel area (640 (H) x 480 (V)) in any position as the processing area within 320,000 pixels.*1	
	Scan mode (valid only when a monochrome camera is connected)		Progressive/interlace switching		
	Capturing start/end line setting function		Enables you to set any capturing start/end line within the image capturing range (for interlace, this specification is made in units of 2 lines). Note, you must specify at least 100 lines when using CV-H200C/H200M.		
Correction functions	Position adjustment		Batch/individual adjustments (up to 128 settings), X, Y, 180° rotation		
	Camera gain adjustment		Camera sensitivity adjustment, offset adjustment, span adjustment (supports settings in 16 tone levels; also supports RGB individual settings when a color camera is connected)		
	White balance adjustment (valid only when a color camera is connected)		Manual setting with white paper		
	Image inversion function		Support of left/right inversion for image capture 9-time repetition for the same type, 13 levels (for binary and difference, 1 level/window)		
Filter function	Count		9-time repetition for the same type, 13 levels (for binary and difference, 1 level/window)		
	Type		Expansion, shrink, averaging, median, edge enhancement, edge extraction X, edge extraction Y, Sobel, Prewitt, Roberts, Laplacian, binary, difference, illumination adjustment, contrast conversion, image extraction, real-time shade correction, blur		
Numerical operation	No. of settings		128 calculation /program		
	Type		Four arithmetic operations, arithmetic function, comparison operator, geometric calculation function, coordinate conversion function, conversion function, logical operator, journalizing function, system function, time axis operation function		
Command memory			1000 rewritable command memories are installed from the external devices and console during operation.		
Statistics analysis	No. of Statistical items		Up to 20000 data points (support of batch save to memory card) Maximum value, minimum value, average value, deviation (3σ), OK/NG count in total judgment		
Support functions	Screen save (valid when monochrome and color cameras are connected)	Internal memory: Up to 1023 screens/1020 screens (240,000-pixel mode) Up to 511 screens/509 screens (310,000-pixel mode) Up to 255 screens/253 screens (1,000,000-pixel mode) Up to 127 screens/124 screens (2,000,000-pixel mode) Up to 50 screens/47 screens (500,000-pixel mode) (Maximum value when one monochrome camera and one color camera are connected and the accumulation condition is "All")	Internal memory: Up to 511 screens/508 screens (240,000-pixel mode) Up to 255 screens/253 screens (310,000-pixel mode) Up to 127 screens/124 screens (1,000,000-pixel mode) Up to 63 screens/60 screens (2,000,000-pixel mode) (Maximum value when one monochrome camera and one color camera are connected and the accumulation condition is "All")	Internal memory: Up to 511 screens/508 screens (240,000-pixel mode) Up to 255 screens/253 screens (310,000-pixel mode). (Maximum value when one monochrome camera and one color camera are connected and the accumulation condition is "All")	
		Programming aid functions	Display aid	Enables you to perform screen display zoom, edge differentiation waveform display, profile display, stain stability display, operation by OCR extraction projection display, and defect level waveform display of trend edge defects during setup or operation.	
	Display template setting function	Batch move	Enables you to collectively move selected windows in X and Y directions during setup.		
		No. of display templates	10 patterns/setting (of the 10 patterns, 4 patterns are the specified values) Possible external switching		
	Screen customization function	Hold image	Enables you to simultaneously display up to 5 screens (when 5-screen horizontal splitting or 5-screen vertical splitting is selected).		
No. of customized screens		Past images (NG images) can be displayed as hold images (up to 3 times before). The measurement result and measurement time can also be referenced (depending on the camera connection status, the displayable count changes from 0 to 3 times).			
Custom menu function			Enables you to create a shortcut menu to an optional setting screen (20 menus/program).		
Operation rewrite function			Enables you to rewrite upper- and lower-limit tolerances and command memories during operation. Supports light dimmer control during operation (when CA-DC20E is connected)		
Memory card save function (SD2 slot only)			Supports measured values, judgment results, NG count, measurement images (can be compressed and saved), saved images (can be compressed and saved), capture images, statistics analysis data, settings (settings can also be saved to the SD1 slot) and direct save during inspection operation		
Others			Image capture function, password function, retest function, file management function, I/O monitor, RS-232C monitor (with the log save function)		
Interface	Control input	External trigger input	2 points, simultaneous 2-camera capturing or individual capturing selectable, EV support, input rating: 26.4 V max., 3 mA min. Individual trigger delays can be set (from 0 to 999 ms) for each trigger input.		Simultaneous capturing of up to 4 cameras or individual capturing selectable (If CV-E500 is not connected, up to 2 monochrome or color cameras can be simultaneously captured).
		Control input	18 points, input rating: 26.4 V max., 2 mA min.		
	Control output	Universal output	27 points (including 2 FLASH output points that work with an external trigger), NPN open collector, 50 mA max. (30 V min.)		
		Total comparator output	1 point, NPN open collector, 50 mA max. (30 V min.) Hold time setting available		
	Monitor output		Analog RGB output, SVGA 800 x 600 (24-bit color, 60 Hz)		
	Run indicator		LED display that works with power supply/ERROR output		
Communication port	PLC link		RS-232C (maximum baud rate: 115200 bps)/Ethernet (1000BASE-T/100BASE-TX/10BASE-T)/USB (USB2.0 HI-SPEED supported) Numerical value output, image data (compressed output available), control I/O available, simultaneous use of 3 ports available		
			Numerical value output that uses RS-232C port, control I/O, and simultaneous use of Ethernet and USB ports available. A series *2 and Q series of Mitsubishi Electric Corporation, and SYSMACC series *2 and CS1/CJ1/CJ2 series of Omron Corporation: Support via each link unit		
Display language			Japanese/English/German selectable		
Illumination control			LED light ON/OFF control (12 V, 24 V) and dimmer control supported when optional Light Controller Unit CA-DC20E is connected. Connect up to 2ch/controller, max. 4 controllers. Supports multiple lighting pattern function.		
Rating	Power supply voltage		24 VDC ±10%		
	Current consumption		2.4 A (2-camera connection and maximum load), 3.2 A (4-camera connection and maximum load)	2.2 A (2-camera connection and maximum load)	
Environmental resistance	Ambient temperature		2-camera connection: 0 to 50°C (32 to 122°F) 1,000,000-pixel or higher camera connection: 0 to 45°C (32 to 113°F)		0 to 50°C (32 to 122°F)
	Relative humidity		35 to 85%, No condensation		
Weight			Approx.1250 g		

*1: Not selectable when CV-H035C/CV-H035M is connected as the pixel area is 310,000 (640 (H) x 480 (V)). *2: Only the RS-232C port is supported.

Camera (CV-H500C/H500M/H200C/H200M)

Model	Camera (CV-H500C/CV-H500M) *4	Camera (CV-H200C/CV-H200M) *4
Image receiving element	2/3-inch color CCD image receiving element, 11x high-speed reading using, square-pixel, 5,050,000 pixels (CV-H500C) 2/3-inch monochrome CCD image receiving element, 11x high-speed reading using, square-pixel, 5,050,000 pixels (CV-H500M) Unit cell size: 3.45 x 3.45 μm 0.14 x 0.14 Mil	1/1.8-inch color CCD image receiving element, 7x high-speed reading using, square-pixel, 2,010,000 pixels (CV-H200C) 1/1.8-inch monochrome CCD image receiving element, 7x high-speed reading using, square-pixel, 2,010,000 pixels (CV-H200M) Unit cell size: 4.4 x 4.4 μm 0.17 x 0.17 Mil
Number of valid pixels	4,990,000 pixels 2432 (H) x 2050 (V)	1,920,000 pixels 1600 (H) x 1200 (V) *5
Scanning system	Progressive (61.2 ms) Interlace: CV-H500M only (40.3 ms)	Progressive (29.2 ms: 2,000,000-pixel mode 24.2 ms: 1,000,000-pixel mode) Interlace: CV-H200M only (16.1 ms: 2,000,000-pixel mode 13.6 ms: 1,000,000-pixel mode)
Pixel transfer frequency	130 MHz (65 MHz x 2 ch)	82 MHz (41 MHz x 2 ch)
Transfer system	Digital serial transfer	
Electronic shutter	1/15, 1/30, 1/60, 1/120, 1/240, 1/500, 1/1000, 1/2000, 1/5000, 1/10000, 1/20000, 0.05 msec to 9000 msec can be set with numeric values	
Lens mount method	C mount	
Environmental resistance	Ambient temperature 0 to 40°C (32 to 104°F)	
	Relative humidity 35 to 85%, No condensation	
Weight	Approx. 130 g (not including lens)	

*4: Only the high-speed camera cable CA-CH3/L/R and CA-CH10/L/R camera cable can be used.

*5: In 1,000,000-pixel mode, 980,000 pixels (1024 x 960) serve as the processing area.

Camera (CV-H035C/H035M)

Model	Camera (CV-H035C/CV-H035M) *6
Image receiving element	1/3-inch color CCD image receiving element, 7x high-speed reading using square-pixel, 340,000 pixels (CV-H035C) 1/3-inch monochrome CCD image receiving element, 7x high-speed reading using square-pixel, 340,000 pixels (CV-H035M) Unit cell size: 7.4 x 7.4 μm 0.29 x 0.29 Mil
Number of valid pixels	310,000 pixels 640 (H) x 480 (V) *7
Scanning system	Progressive (4.7 ms) Interlace: CV-H035M only (2.5 ms)
Pixel transfer frequency	80 MHz 40 MHz x 2ch
Transfer system	Digital serial transfer
Electronic shutter	1/15, 1/30, 1/60, 1/120, 1/240, 1/500, 1/1000, 1/2000, 1/5000, 1/10000, 1/20000, 0.05 msec to 9000 msec can be set with numeric values.
Lens mount method	C mount
Environmental resistance	Ambient temperature 0 to 40°C (32 to 104°F)
	Relative humidity 35 to 85%, No condensation
Weight	Approx. 120 g (not including lens)

*6: Only the high-speed camera cable CA-CH3/L/R and CA-CH10/L/R camera cable can be used.

*7: In 310,000-pixel mode, 310,000 pixels (640 x 480) serve as the processing area. In 240,000-pixel mode, 240,000 pixels (512 x 480) serve as the processing area.

Camera (CV-200C/200M/S200C/S200M)

Model	Camera (CV-200C/CV-200M) *8	Camera (CV-S200C/CV-S200M) *8
Image receiving element	1/1.8 -inch color CCD image receiving element, square-pixel/all-pixel reading, 2,010,000 pixels (CV-200C) 1/1.8 -inch monochrome CCD image receiving element, square-pixel/all-pixel reading, 2,010,000 pixels (CV-200M) Unit cell size: 4.4 x 4.4 μm 0.17 x 0.17 Mil	1/1.8 -inch color CCD image receiving element, square-pixel/all-pixel reading, 2,010,000 pixels (CV-S200C) 1/1.8 -inch monochrome CCD image receiving element, square-pixel/all-pixel reading, 2,010,000 pixels (CV-S200M) Unit cell size: 4.4 x 4.4 μm 0.17 x 0.17 Mil
Number of valid pixels	1,920,000 pixels 1600 (H) x 1200 (V) *9	
Scanning system	Progressive (58.5 ms: 2,000,000-pixel mode, 47.6 ms: 1,000,000-pixel mode) Interlace: CV-200M only (32.7 ms: 2,000,000-pixel mode, 27 ms: 1,000,000-pixel mode)	Progressive (58.5 ms: 2,000,000-pixel mode, 47.6 ms: 1,000,000-pixel mode) Interlace: CV-S200M only (32.7 ms: 2,000,000-pixel mode, 27 ms: 1,000,000-pixel mode)
Pixel transfer frequency	40 MHz	
Transfer system	Digital serial transfer	
Electronic shutter	1/15, 1/30, 1/60, 1/120, 1/240, 1/500, 1/1000, 1/2000, 1/5000, 1/10000, 1/20000, 0.05 msec to 9000 msec can be set with numeric values.	
Lens mount method	C mount	Special mount (M15.5 P0.5 male)
Environmental resistance	Ambient temperature 0 to 40°C (32 to 104°F)	Head: 0 to 40°C (32 to 104°F), relay unit: 0 to 40°C (32 to 104°F) (however, 35°C (95°F) max. in partial capturing 50 lines or lower)
	Relative humidity 35 to 85%, No condensation	
Weight	Approx. 110 g (not including lens)	Head: Approx. 210 g (including the cable, not the lens), relay unit: Approx. 70 g

*8: The CA-CN17 camera cable (17M) 55.8' and the CA-CN17R high-flex camera cable (17M) 55.8' cannot be used.

*9: In 1,000,000-pixel mode, 980,000 pixels (1024 x 960) serve as the processing area.

Camera (CV-035C/035M/S035C/S035M)

Model	Camera (CV-035C/CV-035M)	Camera (CV-S035C/CV-S035M) *10
Image receiving element	1/3 -inch color CCD image receiving element, 2x high-speed reading using square-pixel, 350,000 pixels (CV-035C) 1/3 -inch monochrome CCD image receiving element, 2x high-speed reading using square-pixel, 350,000 pixels (CV-035M) Unit cell size: 7.4 x 7.4 μm 0.29 x 0.29 Mil	1/3 -inch color CCD image receiving element, 2x high-speed reading using square-pixel, 350,000 pixels (CV-S035C) 1/3 -inch monochrome CCD image receiving element, 2x high-speed reading using square-pixel, 350,000 pixels (CV-S035M) Unit cell size: 7.4 x 7.4 μm 0.29 x 0.29 Mil
Number of valid pixels	320,000 pixels 657 (H) x 492 (V) *11	
Scanning system	Progressive (16 ms) Interlace: CV-035M only (8.8 ms)	Progressive (16 ms) Interlace: CV-S035M only (8.8 ms)
Pixel transfer frequency	24.5 MHz	
Transfer system	Digital serial transfer	
Electronic shutter	1/15, 1/30, 1/60, 1/120, 1/240, 1/500, 1/1000, 1/2000, 1/5000, 1/10000, 1/20000, 0.05 msec to 9000 msec can be set with numeric values.	
Lens mount method	C mount	Special mount (M10.5 P0.5 male)
Environmental resistance	Ambient temperature 0 to 50°C (32 to 122°F)	Head: 0 to 50°C (32 to 122°F), relay unit: 0 to 40°C (32 to 104°F)
	Relative humidity 35 to 85%, No condensation	
Weight	Approx. 100 g (not including lens)	Head: Approx. 160 g (including the cable, not the lens), relay unit: Approx. 70 g

*10: The CA-CN17 camera cable (17M) 55.8' and the CA-CN17R high-flex camera cable (17M) 55.8' cannot be used.

*11: In 310,000-pixel mode, 310,000 pixels (640 x 480) serve as the processing area. In 240,000-pixel mode, 240,000 pixels (512 x 480) serve as the processing area.

Dimensions

Unit : mm inch

Controller CV-5702/CV-5502/CV-5002

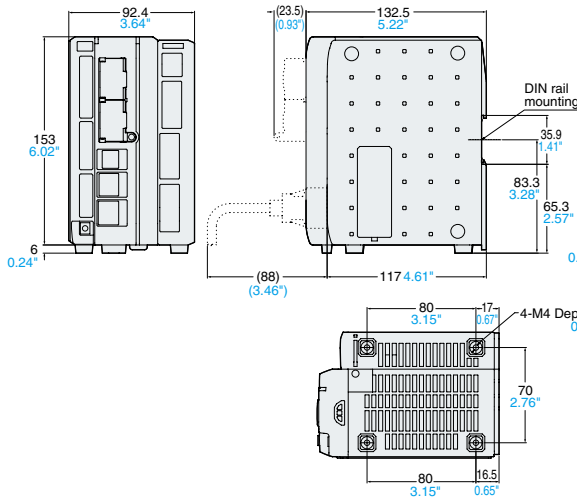

When camera expansion unit CV-E500 is installed (CV-5702/CV-5502 only)

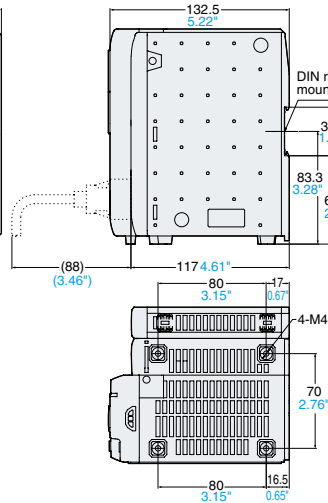

Console

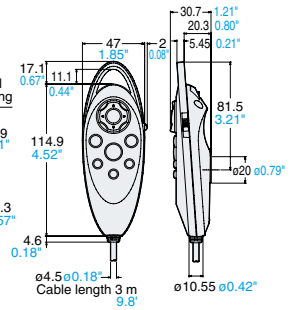

Light Expansion Unit CA-DC20E

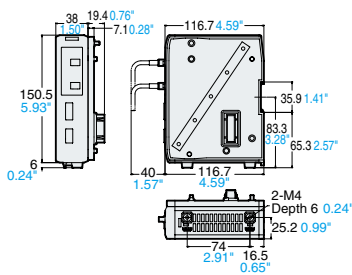

CV-5002 + CA-DC20E

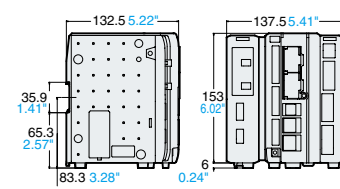

CV-5702 + CV-E500 + CA-DC20E (4 units)

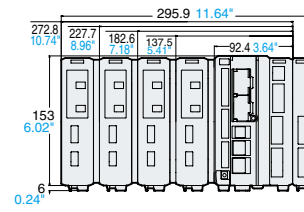

Camera CV-S035CH/CV-S035MH

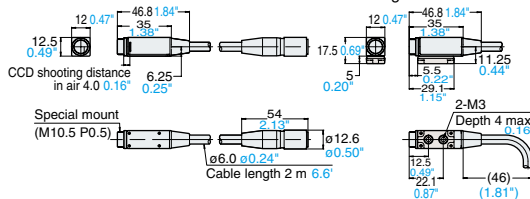

When using a mounting bracket

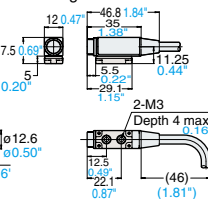

Lens CA-LSx

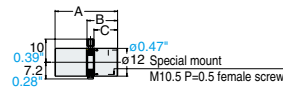

	CA-LS4	CA-LS6	CA-LS16	CA-LS30
A	16.7 0.66"	21.3 0.84"	20.4 0.80"	27.1 0.66"
B	11.5 0.45"	15.9 0.63"	10.2 0.40"	13.2 0.52"
C	8.5 0.33"	12.9 0.51"	7.2 0.28"	10.2 0.40"

Polarization filter OP-51502

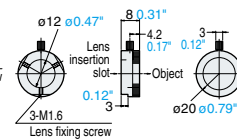

Side viewer attachment OP-51503

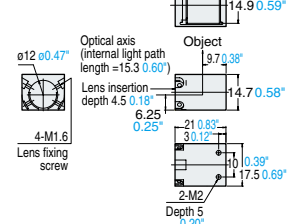

Camera CV-S200CH/CV-S200MH

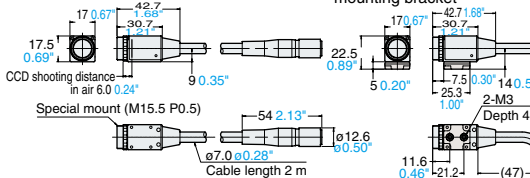

When using a mounting bracket

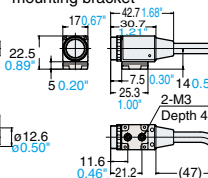

Close-up ring OP-51500 (5 mm 0.20") / OP-51501 (10 mm 0.39") / OP-66830 (5 mm 0.20") / OP-66831 (10 mm 0.39")

	OP-51500	OP-51501	OP-66830	OP-66831
A	5 0.20"	10 0.39"	5 0.20"	10 0.39"
B	8 0.31"	13 0.51"	8 0.31"	13 0.51"
C	12 0.47"	12 0.47"	17 0.67"	17 0.67"
D	M10.5 P=0.5 female screw	M15.5 P=0.5 female screw	M10.5 P=0.5 female screw	M15.5 P=0.5 female screw
E	M10.5 P=0.5 male screw	M15.5 P=0.5 male screw	M10.5 P=0.5 male screw	M15.5 P=0.5 male screw

Polarization filter OP-66832

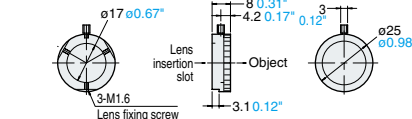

Side viewer attachment OP-66833

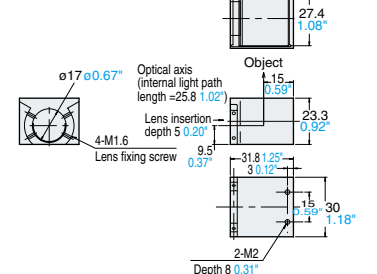

Lens CA-LHSx

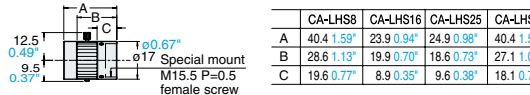

	CA-LHS8	CA-LHS16	CA-LHS25	CA-LHS50
A	40.4 1.59"	23.9 0.94"	24.9 0.98"	40.4 1.59"
B	28.6 1.13"	19.9 0.70"	18.6 0.73"	27.1 1.07"
C	19.6 0.77"	8.9 0.35"	9.6 0.38"	18.1 0.71"

Camera CV-035C/CV-035M

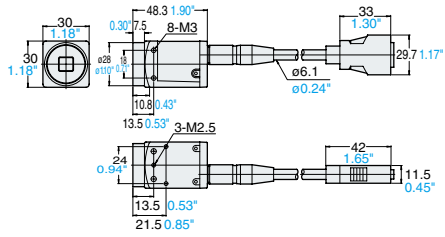

When using a mounting bracket

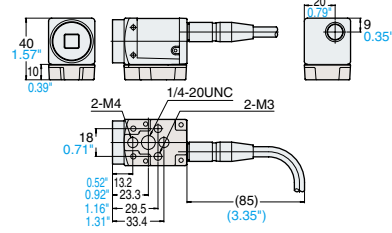

Camera Control Unit CV-S200CU/CV-S200MU / CV-S035CU/CV-S035MU

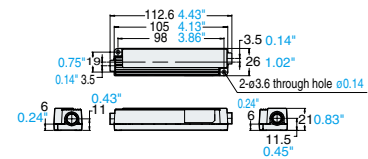

With cable connected

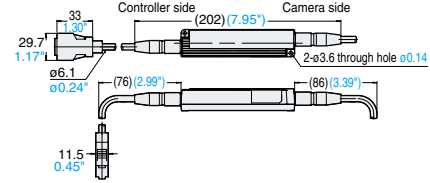

Camera CV-H500C/CV-H500M/CV-H200C/CV-H200M/CV-200C/CV-200M/CV-H035C/CV-H035M

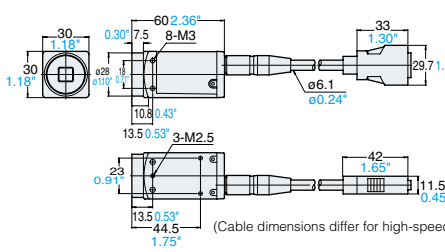

When using a mounting bracket

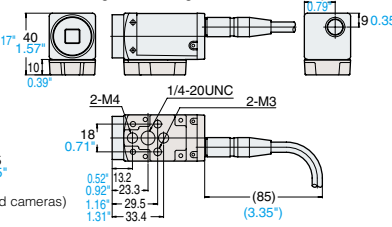

(Cable dimensions differ for high-speed cameras)

L-shaped connector camera cable
CA-CN3L (3M) 9.8' / CA-CN10L (10M) 32.8' / CA-CN17L (17M) 55.8'
L-shaped connector cable for high-speed cameras
CA-CH3L (3M) 9.8' / CA-CH10L (10M) 32.8'

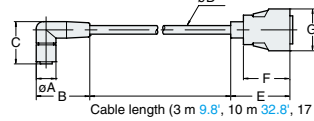

Cable length (3 m 9.8', 10 m 32.8', 17 m 55.8')

	A	B	C	D	E	F	G							
L-shaped connector camera cable CA-CNxL	14.0	55	38	1.50	30	1.18	6.10	24	42	1.65	33	1.30	29.7	1.17
L-shaped connector cable for high-speed cameras CA-CHxL	14.0	55	38	1.50	30	1.18	7.20	28	41	1.61	31	1.22	31.4	1.24

Camera cable

CA-CN1 (1M) 3.3' / CA-CN3 (3M) 9.8' / CA-CN10 (10M) 32.8' / CA-CN17 (17M) 55.8'

High-flex camera cable

CA-CN3R (3M) 9.8' / CA-CN10R (10M) 32.8' / CA-CN17 (17M) 55.8'

Cable dedicated for high-speed cameras

CA-CH3 (3M) 9.8' / CA-CH10 (10M) 32.8'

High-flex cable dedicated for high-speed cameras

CA-CH3R (3M) 9.8' / CA-CH10R (10M) 32.8'

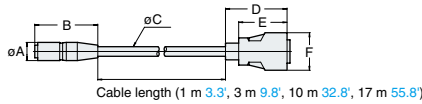

Cable length (1 m 3.3', 3 m 9.8', 10 m 32.8', 17 m 55.8')

	A	B	C	D	E	F						
CA-CNx	12.5	0.49	43	1.69	6.1	0.24	42	1.65	33	1.30	29.7	1.17
CA-CNxR	14.0	0.55	54	2.13	6.6	0.28	42	1.65	33	1.30	29.7	1.17
CA-CHx	12.5	0.49	43	1.69	7.2	0.28	41	1.61	31	1.22	31.4	1.24
CA-CHxR	14.0	0.55	54	2.13	7.6	0.30	41	1.61	31	1.22	31.4	1.24

Lens Selection Charts

CV-H200C/CV-H200M

CV-200C/CV-200M

(When CA-LH Series is installed)

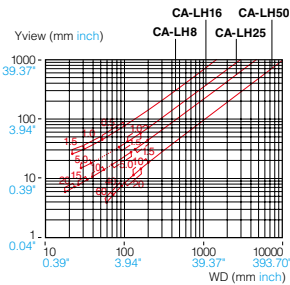

CV-H200C/CV-H200M

CV-200C/CV-200M

(When CV-L Series is installed)

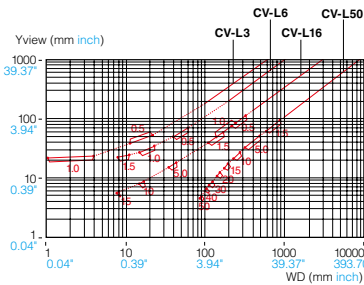

CV-H500C/CV-H500M

(When CA-LH Series is installed)

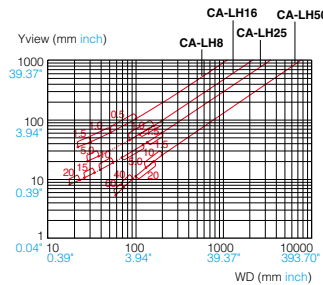

CV-035C/CV-035M

CV-H035C/CV-H035M

(When CA-LH Series is installed)

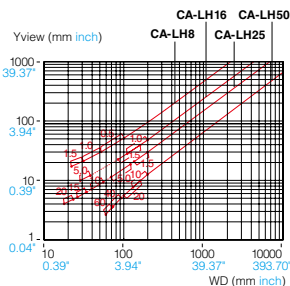

CV-035C/CV-035M

CV-H035C/CV-H035M

(When CV-L Series is installed)

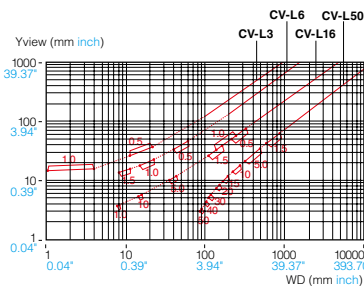

CV-S035C/CV-S035M

(When CA-LS Series is installed)

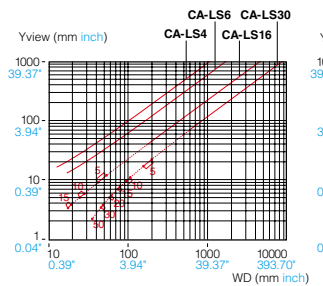

CV-S200C/CV-S200M

(When CA-LHS Series is installed)

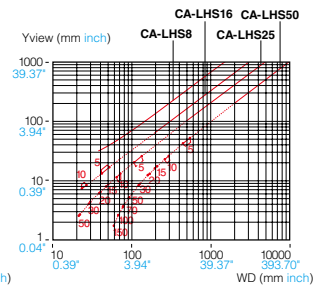

Values in the table are merely reference values; adjustments may be required during installation.

All-in-One Image Processing CV-700 Series



Features

- Color and Grayscale processing for any application
- Built-in monitor and 2 camera connectivity for easy integration
- Simple touch panel user interface

Simple, Straightforward Programming Designed for Easy Operation

Simple Programming helps for quick and efficient on-site operation, reducing set-up costs.



The All-in-One Design Saves Space and Reduces Wiring

The CV-751 comes standard with a built-in 5.5" TFT color monitor and an array of on-board I/O options, such as discrete, analog, and RS-232 communications. The system can be configured via a remote console or a built-in touch panel.

High-Speed Search & Sub-pixel Measurement

Special ASIC technology ensures accurate measurement by using sub-pixel processing and a fast 360° rotation search.

Comprehensive menus

Menus are available for nearly every in-line need. Up to 8 different inspection modes can be combined in a single program.

Applications Menu

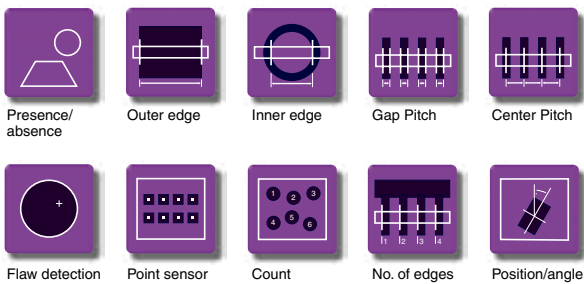

The principle of color Shade-Scale processing

Color Shade-Scale processing recognizes the differences in hue and intensity of shade levels.

After clicking on a target to extract its color, the entire image is converted to a shade hierarchy with the extracted color as the top level.

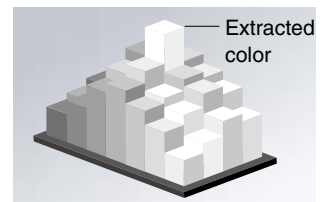



Click on the target point for color extraction.

The whole image is converted into a gray shade image with the extracted color as the top level.

Specifications

Controller

Type		Built-in monitor type	Separate monitor type	
		CV-751(P)	CV-701(P)	
Model		*Input with a remote control console (optional) is also available. 		
No. of pixels		508 (H) x 480 (V)		
Process cycle		30 c/s (Varies depending on the setting)		
Binary level		Color binary processing by color extraction or color shade processing Color can be specified individually for each window		
Program registration		16 programs (8 programs when two cameras are used) (Programs are externally selectable)		
No. of registered screens		16 screens (1 screen/program or 2 screens/program)		
Functions	Mode	Area sensor	8 max./program, Window shape: Circle/square/free square	
		Absolute position detection	4/program, Window shape: Square	
		Relative position detection	4/program, Window shape: Square	
		Inspection mode	Width measurement	8/program, Window shape: Square
			Pitch measurement	8/program, Window shape: Square
			Edge count	8/program, Window shape: Square
			Count	8/program, Window shape: Square/circle
			Flaw detection	8/program, Window shape: Square/circle/ring/arc
			Point sensor	8/program, 8 points/Window
	Center-of-gravity	8/program, Window shape: Square/circle		
	Adjustment	Position adjustment	Color shade search/Line sensor/Color binary processing (Center of gravity, Major axis inclination, X-/Y-axis direction, ±180° rotation)	
		Illumination adjustment	1 illumination adjustment window/program (two when two cameras are connected)	
		Pre-processing (Filter function)	Expand, Shrink, Median, Average, Edge enhancement, Edge detection, Shading, Lightness-up, Saturation-up, Invert	
	Auto-sequence		Continuous processing of 4 programs max. (Up to 32 inspections [4 programs x 8 windows] can be continuously processed)	
	Data calculation		Unit conversion and offset	
Screen save		8 screens		
Setup menu		Stores parameters of initial setting		
Input	Camera input		2	
	Control input	External trigger	1 (Non-voltage input)	
		Program selection	Data input (x4), 16 programs selectable (Non-voltage input)	
		Continuous detection	Detection continued without an external trigger when the program No. is changed while CONT input is ON. (Non-voltage input)	
		Screen registration	2, Screen is registered by a trigger signal while REC input is ON. (Non-voltage input)	
		Display/output window selection	Data input (x3), 8 windows selectable (Non-voltage input)	
LCD monitor	Panel	TFT 5.5 inch, full color	Not provided	
	Backlight	Cold cathode fluorescent tube (Average life: Approx. 40000 hrs)	Not provided	
Memory card		Compact Flash memory		
Video output		Conforms to NTSC standards		
RS-232C interface		1 ch, Numerical value output and control input/output (Baud rate: 38400 bps max. selectable)		
Control output		NPN	NPN open-collector: 9, 50 mA max. (30 V max.)	
		PNP	PNP open-collector: 9, 50 mA max. (30 V max.)	
Numerical value output		Binary 13 bits, 10 mA max. (30 V max.)		
Analog output		0 to 4 V output, Output impedance: 100 Ω		
Display language		English/Japanese selectable		
Power supply voltage		24 VDC±10%		
Current consumption		1.4 A	700 mA	
Ambient temperature		0 to 40°C (32 to 104°F), No freezing		
Relative humidity		35 to 85%, No condensation		
Weight		Controller: Approx. 900 g	Controller: Approx. 400 g, Remote control console: Approx. 160 g	

Camera

Type	CV-070
Image pickup element	1/3 inch CCD video element, Square-pixel all reading
Electronic shutter	1/30, 1/50, 1/60, 1/100, 1/125, 1/250, 1/500, 1/1000, 1/2000, 1/4000, 1/10000
Lens mount method	C mount
Ambient temperature	0 to 40°C (32 to 104°F), No freezing
Relative humidity	35 to 85%, No condensation
Weight	Camera: Approx. 310 g (including 3-m (9.8') cable)

System Configurations

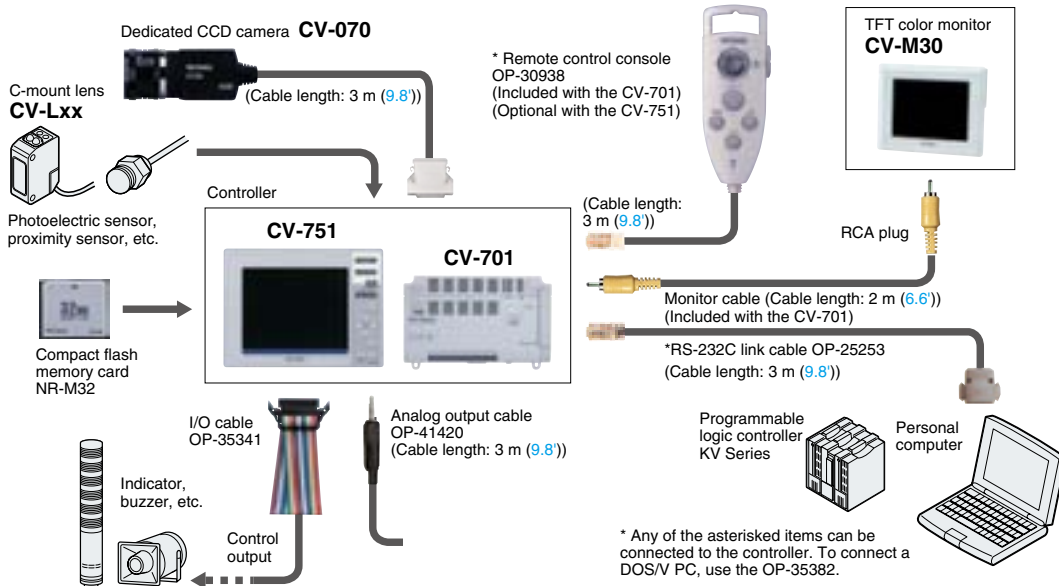





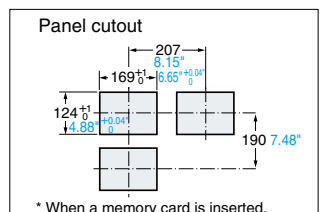
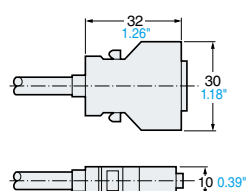
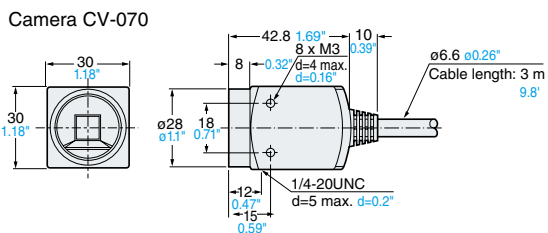
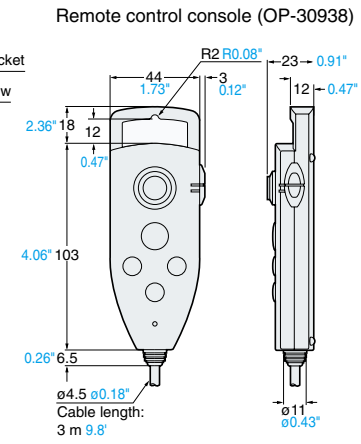
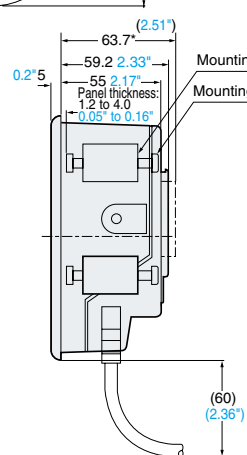
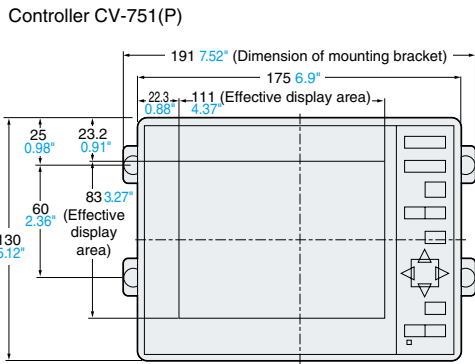
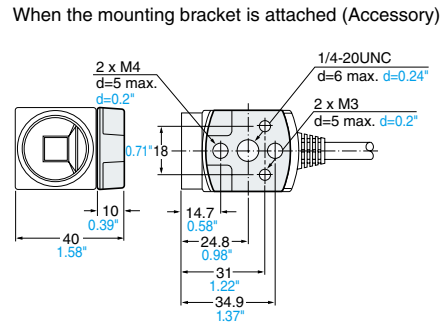
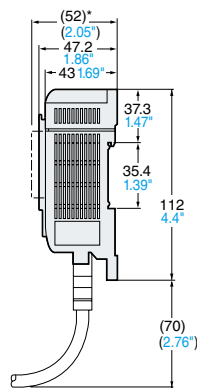
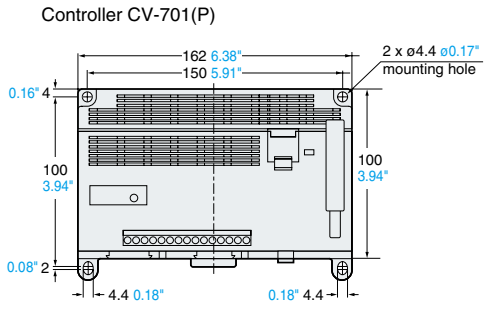



Dimensions

Unit: mm inch



Illumination

Selection Guide

Model	Description	Application	Page
CA-DB 	Bar light	Indirect lighting eliminates glare and applies illumination evenly	P.36
CA-DX 	Coaxial vertical-light	Enhances the edge of the imprinting against the reflective surface	
CA-DL 	Low-angle light	Sharpens the contrast of edges and uneven surfaces	P.37
CA-DD 	Dome light	Indirect light allows clear images without hot spots	
CA-DS 	Backlight	Utilizing the silhouette enables high-accuracy transparent target detection	P.38
CA-DR 	Direct-ring light	General-purpose lighting for various applications.	
CV-R/CA-R 	Inverted high-frequency light	Lights for large-sized targets.	
CA-DC100 	Controller	LED Illumination Controller	P.40

Technical Information

Color lighting	_____	P.41
	_____	P.42
Strobe light & wiring	_____	P.42
Polarization filter	_____	P.43
Direct reflection and diffuse reflection	_____	P.44

CA-DB



Indirect lighting eliminates glare and applies illumination evenly

Detecting defective plating of terminals

Detects imperfect plating on the tips of terminals. Color image processing enables differentiation between the bare silver metal and the gold plating.

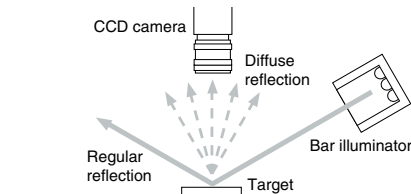

Lighting technique using a bar light

The bar light illuminator applies uniform light on long targets. Applying the light from an angle creates diffuse reflection, allowing for easy differentiation. If the surface is very glossy, a polarizing filter is recommended.

APPLICATION

DETECTING THE POSITION OF STICKERS

With direct reflection



Since the sticker reflects the illumination, the edges are not clear.



With bar illumination

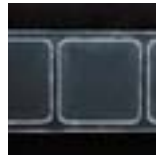

Only the edges are extracted. The position detection of stickers can be precisely carried out.

MEASURING THE INTERVALS OF CONNECTOR TERMINALS

With direct reflection



There is no contrast between the edge of terminals and the molded area.



With bar illumination



Since only the edges of the terminals appear bright, the edge position can be detected.

CA-DX



Enhances the edge of imprinting against a reflective surface

Detecting imprints on press-molded parts

Product number and specification imprints can be recognized by their patterns. Incorrect stamping and mixing of different products can also be detected.

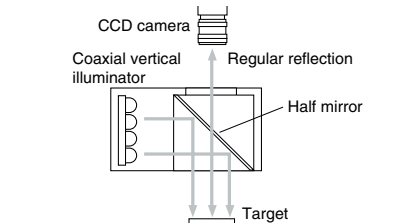

Lighting technique using a coaxial vertical-light

The coaxial vertical illuminator applies light on the same axis as the lens. The contrast between dark and bright parts is captured and differentiated by allowing the reflected light from the glossy surface into the camera, while blocking the diffuse light at the edge of the imprint.

APPLICATION

DETECTING AN ENGRAVED MARK ON A METAL SURFACE

With direct reflection



The engraved mark is not stably detected due to irregular reflection.



With coaxial vertical illumination



The engraved mark appears dark and detection is stable.

INSPECTION OF GLASS COMPONENTS

With direct reflection



The glass surface reflects the illumination.



With coaxial vertical illumination



Since the entire surface is evenly illuminated, defects such as stains or flaws can be detected.

CA-DL

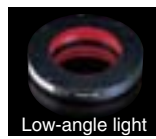

Sharpens the contrast of edges and uneven surfaces

Detecting chips on rubber packaging

Detects minute defects such as chips on a perimeter edge, surface flaws or deviations in thickness.

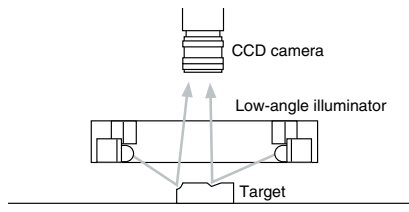

Lighting technique using a low-angle-light

The low-angle illuminator allows differentiation by applying light at an angle onto the edge of the surface.

APPLICATION

DETECTING A CHIP ON A RUBBER WASHER

With direct reflection



The chip on the edge is not clear.



With low-angle illumination



The chip on the edge appears bright and is clearly recognized.

DETECTING A CHIP THROUGH FILM

With direct reflection



The film reflects the light unevenly, disrupting the inspection.



With low-angle illumination

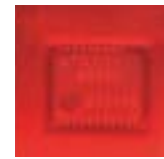

The characters are clearly highlighted.

CA-DD



Indirect light allows clear images without hot spots

Detecting printing on aluminum packaging material

Detection is normally difficult or impossible due to the hot spots generated from surface irregularities or glare caused by the film sheet.

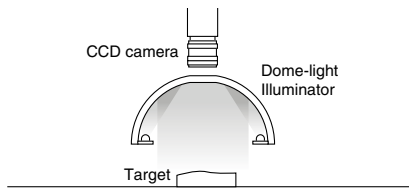

Lighting technique using a dome-light

The dome-light illuminator casts indirect light from various directions. Since soft diffuse light can be applied uniformly over a target with an irregular shape, the surface condition can be kept uniform, making contrast of inspection points clear.

APPLICATION

DETECTING PRINT ON AN ALUMINUM PACKAGE

With direct reflection



The print is not detected because of glare on the package.



With dome illumination



Glare is effectively eliminated by evenly illuminating the surface, allowing the print to appear with high contrast.

DETECTING MARKS ON THE BOTTOM OF A CAN

With direct reflection



The print is not detected because of irregular reflection from the curved can bottom.



With dome illumination



The curved surface is evenly illuminated and the print can be detected.

CA-DS

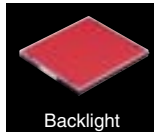

Utilizing the silhouette enables high-accuracy transparent target detection

Detecting the level of transparent liquid

Detects the level of a clear liquid substance in a transparent or semi-transparent container.

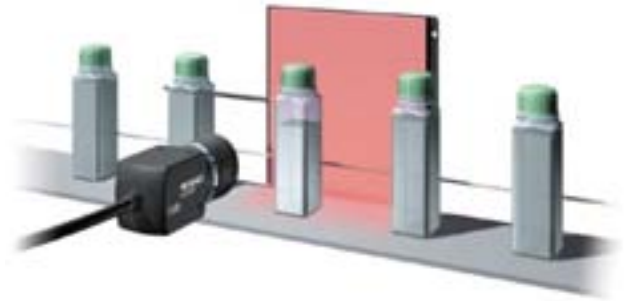
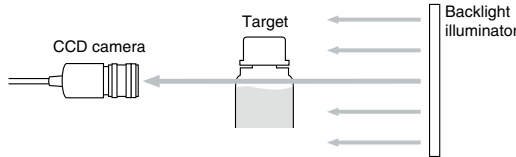

Lighting technique using a backlight

The backlight illuminator silhouettes the shape of the target using the light passing through the target.

APPLICATION

MEASURING THE SIZE OF A LEAD TERMINAL

With direct reflection

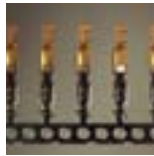

Some edges are not clear.

With backlight illumination

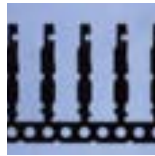

The complicated contour becomes a sharp silhouette so that shape and size measurements can be conducted.

DETECTING FOREIGN OBJECTS IN UNWOVEN FABRIC

With direct reflection



There is no clear contrast between the flaw and the background

With backlight illumination



The silhouette of the foreign object enables a stable measurement.

CA-DR



General-purpose lighting for various applications.

The circularly arranged LEDs provide equal lighting suitable for many applications.



CV-R/CA-R Lights for large-sized targets.



These fluorescent illuminators use an inverter method and are excellent for image processing. The large ring light provides optimal lighting for large-sized targets.



MODEL	CV-R11	CA-R20
Lighting method	Inverted high-frequency lighting (25 to 35 KHz)	
Luminescent color of lamp	N-EX (daylight white color)	
Dimension of lamp	Outside diameter: ø80 mm ø3.15", Inside diameter: ø56 mm ø2.21"	Outside diameter: ø200 mm ø7.88", Inside diameter: ø176 mm ø6.93"
Lamp life ^{*1}	Approx. 2000 hours average	Approx. 1500 hours average
Power supply voltage	24 VDC ±10%	
Current consumption	0.7 A	1.5 A
Ambient temperature	5 to 50°C (41 to 122°F)	5 to 40°C (41 to 104°F)
Relative humidity	35 to 90% (No condensation)	
Weight	Illumination unit: Approx. 150 g Controller: Approx. 650 g (including cable)	Illumination unit: Approx. 300 g Controller: Approx. 900 g (including cable)
Model of replacement lamp	OP-25526	

*1: The lamp life refers to the average time it takes for the illumination intensity to drop to 70% of the initial illumination intensity² when the lamp is illuminated continuously in a vibration-free environment with an ambient temperature of 25°C (77°F). Note that the life may be shorter according to the conditions of the use environment.

*2: The initial illumination intensity refers to the illumination intensity measured at the moment when the lamp is turned on for the first time.

*3: Consult your sales representative for conformity of the model to CE Marking.

CV-R11 Illumination unit (When the mounting bracket (L) is attached.)

Controller

CA-R20 Illumination unit

Unit: mm inch
Controller

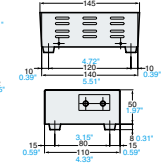
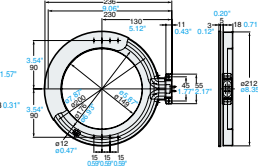
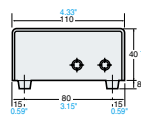
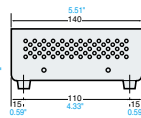
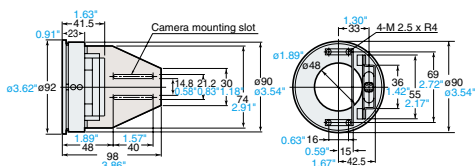

LED illumination units

Unit: mm inch

Bar light CA-DB

MODEL	LED color	Weight (g)	Power consumption (w)
CA-DBR5	Red	Approx. 35	1.7
CA-DBW5	White	Approx. 40	2.9
CA-DBB5	Blue	Approx. 40	2.9
CA-DBR13	Red	Approx. 80	4.2
CA-DBW13	White	Approx. 90	7.3
CA-DBB13	Blue	Approx. 90	7.3



CA-DBxxx

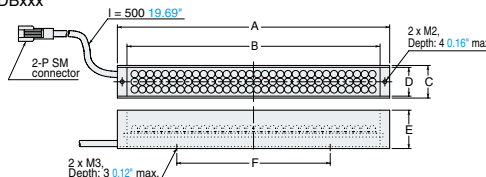

MODEL	Dimensions					
	A	B	C	D	E	F
CA-DBx5	60	50	17	15	20	30
	2.36"	1.97"	0.67"	0.59"	0.79"	1.18"

MODEL	Dimensions					
	A	B	C	D	E	F
CA-DBx13	142	132	17	15	20	80
	5.59"	5.20"	0.67"	0.59"	0.79"	3.15"

Coaxial vertical light CA-DX

MODEL	LED color	Weight (g)	Power consumption (w)
CA-DXR5A	Red	Approx. 230	5
CA-DXW5A	White	Approx. 230	4.9
CA-DXB5A	Blue	Approx. 230	4.9
CA-DXR7	Red	Approx. 380	6.7
CA-DXW7	White	Approx. 380	10.1
CA-DXB7	Blue	Approx. 380	10.1



MODEL	Dimensions						
	A	B	C	D	E	F	G
CA-DXx5	97	60	36	32	16	59	40
	3.82"	2.39"	1.42"	1.26"	0.63"	2.32"	1.57"
CA-DXx7	120	82	50	50	17	79	60
	4.72"	3.22"	1.97"	1.97"	0.67"	3.11"	2.36"

MODEL	Dimensions						
	H	I	J	K	L	M	N
CA-DXx5	32	10	15	80	40	—	—
	1.26"	0.39"	0.59"	3.15"	1.57"	—	—
CA-DXx7	50	11	14	—	—	50	55
	1.97"	0.43"	0.55"	—	—	1.97"	2.17"

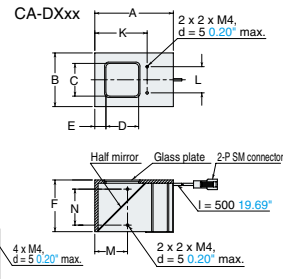

Low-angle light CA-DL

MODEL	LED color	Weight (g)	Power consumption (w)
CA-DLR7	Red	Approx. 40	2
CA-DLR12	Red	Approx. 85	3.3



CA-DLR7/12

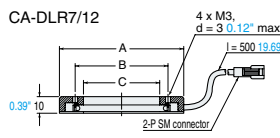

MODEL	Dimensions		
	A	B	C
CA-DLR7	ø75 ø2.95"	ø56 ø2.20"	ø46 ø1.81"
CA-DLR12	ø125 ø4.92"	ø110 ø4.33"	ø95 ø3.74"

Dome light CA-DD

MODEL	LED color	Weight (g)	Power consumption (w)
CA-DDR15	Red	Approx. 130	11
CA-DDW15	White	Approx. 170	18.8
CA-DBB15	Blue	Approx. 170	18.8



CA-DDx15

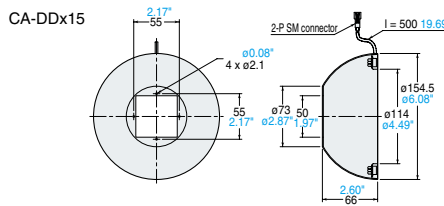

Backlight CA-DS

MODEL	LED color	Weight (g)	Power consumption (w)
CA-DSR3	Red	Approx. 40	3.6
CA-DSW3	White	Approx. 40	5.8
CA-DSB3	Blue	Approx. 40	5.8
CA-DSR9	Red	Approx. 110	14
CA-DSW7	White	Approx. 90	18
CA-DSB7	Blue	Approx. 90	18



CA-DSx3

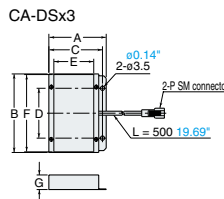

MODEL	Dimensions						
	A	B	C	D	E	F	G
CA-DSR3	46	63	43	40	32	62	8.2
	1.81"	2.48"	1.69"	1.57"	1.26"	2.44"	0.32"
CA-DSW3	46	63	43	40	32	62	11.7
	1.81"	2.48"	1.69"	1.57"	1.26"	2.44"	0.46"
CA-DSB3	46	63	43	40	32	62	11.7
	1.81"	2.48"	1.69"	1.57"	1.26"	2.44"	0.46"

CA-DSx7/9

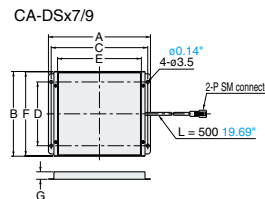

MODEL	Dimensions						
	A	B	C	D	E	F	G
CA-DSR9	112	93	106	70	92	92	8.2
	4.41"	3.68"	4.17"	2.76"	3.62"	3.62"	0.32"
CA-DSW7	97	78	91	60	77	77	11.7
	3.82"	3.07"	3.58"	2.36"	3.03"	3.03"	0.46"
CA-DSB7	97	78	91	60	77	77	11.7
	3.82"	3.07"	3.58"	2.36"	3.03"	3.03"	0.46"

The dimensions of the light-emitting surface are shown in columns E and F.

Direct-ring light CA-DR

MODEL	LED color	Weight (g)	Power consumption (w)
CA-DRR4F	Red	Approx. 20	1.5
CA-DRW4F	White	Approx. 20	2.9
CA-DRB4F	Blue	Approx. 20	2.9
CA-DRR10F	Red	Approx. 90	8.3
CA-DRW10F	White	Approx. 80	7.9
CA-DRB10F	Blue	Approx. 80	7.9



CA-DRx4F

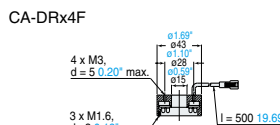

* When the mounting bracket is attached (CA-DRx9/10F)

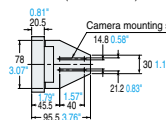

CA-DRx10F

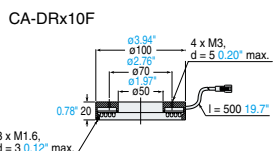

LED Illumination CA-D Series



LED Illumination Controller



CA-DC100

High frequency lights

The high light-emitting frequency of 100 kHz ensures consistent image capture even under high-speed shutter mode on high-speed lines.

Limit function to ensure safety [INDUSTRY FIRST]

The limit function prevents light emission from exceeding approx. 60% of the maximum light intensity. This function prevents the LED life from being shortened due to the light intensity being set to excessive levels.

Light adjustment trimmer for fine-tuning

The CA-DC100 features a light adjustment trimmer that allows fine adjustment of the light intensity to achieve optimal irradiation volume. The CA-DC100 also allows the user to switch light emission on and off by external inputs.

Specifications

MODEL	CA-DC100	
Output	Light control method	Light-emitting frequency: 100 kHz, pulse width modulation method
	Number of outputs	2 channels
	Voltage	12 V
	Capacitance	30 W max. (20 W per channel)
Input		External control input (EXT), 2 contacts (non-voltage contact input)
Power supply voltage		24 VDC ±10%
Current consumption		1.8 A (under maximum load)
Ambient temperature		0 to 45°C (32 to 113°F)
Relative humidity		35 to 85% No condensation
Weight		Approx. 220 g

* Environment for illumination unit: Ambient temperature of 0 to 40°C (32 to 104°F) and relative humidity of 35 to 65% (no condensation).

2-channel connection for a wide range of applications [INDUSTRY FIRST]

Two illumination units can be connected to a single controller. Switching between the two illuminators makes compound inspections and 2-line inspections easy and low cost.

DIN-rail mountable design

The CA-DC100 can be mounted on a DIN rail for easy on-site installation. In addition, various mounting brackets (sold separately) enable installation in various environments.

Dimensions

CA-DC100

Unit: mm inch

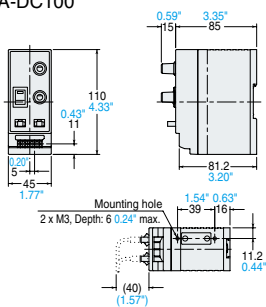

Bottom mounting (with OP-42169)

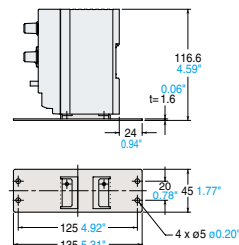

Front mounting (with OP-42168)

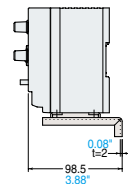
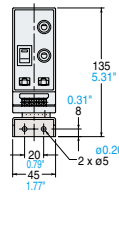

Side mounting (with OP-42170)

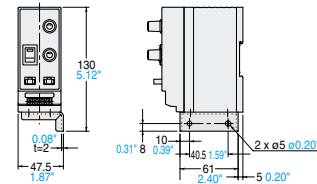

* The mounting brackets OP-421xx are sold separately.

Options

Diffuser



For LED reflection prevention

Eliminates the reflection of LEDs and inconsistencies generated in capturing the image of glossy targets. (Compatible with direct-ring and bar lights)

MODEL	Compatible illuminator
OP-42282	CA-DBx13
OP-42283	CA-DBx5
OP-42337	CA-DRx4F
OP-42339	CA-DRx10F

Extension cable

Cable length (m)	MODEL
2 6.6'	CA-D2
5 16.4'	CA-D5

Precautions for use of LED illumination

- Continuous operation under high temperature and high humidity accelerates the reduction and deterioration of light intensity.
- Reduce heat generation of the product.

Use the limit function and light-control volume.

When used at the maximum light intensity, the product will produce a greater amount of heat, which will have a negative effect on the operating life. It is recommended that the limit function be turned on or the light-control volume be set to 40 to 60%. (Standard features of the CA-DC100.)

Turn on the LED only when capturing images.

It is recommended to use the on/off external switching function (Standard feature of the CA-DC100) to turn on illumination in sync with image-capturing. *LED is resistant to switching operation and will not deteriorate when turned on and off repeatedly.

Use the product in an optimum environment for heat radiation and cooling.

Take measures such as installing cooling air and fans or using mounting brackets with good heat-transfer properties.

Common specifications of LED illumination unit

Ambient temperature	0 to 40°C (32 to 104°F)
Relative humidity	35 to 65% (No condensation)

ILLUMINATION SOLUTIONS

Color lighting

Complementary color

Detection using complementary colors

The contrast between the red candy wrapper and the carton is compared with a white, red, or blue LED light.

Target



With white LED

Contrast is not clear as objects have homogeneous brightness.



With red LED

The red object is slightly brighter than the carton.



With blue LED

The red object appears darker than the carton and detection can be stably carried out.



Hue circle

Position of opposing colors in the complementary color hue circle

The contrast of the image is produced by **the complementary colors** of the illumination to the candy wrapper.

Contrast between gold and silver colors

To obtain a clear contrast between gold and silver colors, blue illumination is more efficient than red illumination as blue is a complementary color to gold.



With color camera



With color camera and red light



With color camera and blue light



With monochrome camera and red light



With monochrome camera and blue light
clear contrast is created between gold and silver.

Characters on a chip carrier tape

Inspecting characters printed on a chip through a film. Since red has higher transmission (low scattering rate) than blue, red illumination produces clear contrast.



With color camera



With color camera and red light



With color camera and blue light

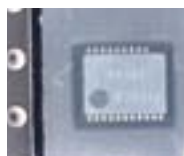

With monochrome camera and red light
clear contrast is created through the film.

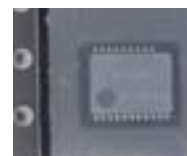

With monochrome camera and blue light
less contrast is created.

Scattering rate

Blue light from an angle



Stain area
2749

Red light from an angle

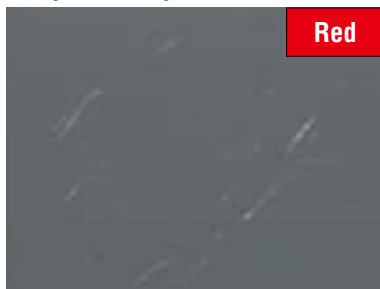

Stain area
786

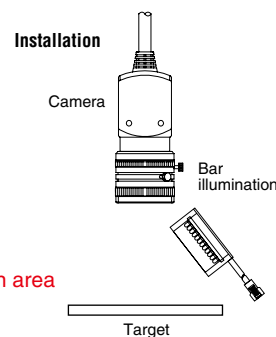

To obtain a clear contrast with LED illumination, the scattering rate can be used along with color relation (complementary/similar colors). Blue light has a short wavelength and a high scattering rate. In contrast, red light has a long wavelength, low scattering rate and a high transmission. Light with a high scattering rate is effective to detect surface conditions as shown in the pictures.

When using a blue light with its high scattering rate, there is a larger amount of diffuse reflection on the stain, which allows the stains to be detected more easily.

Color lighting

CCD camera sensitivity

CCD sensitivity is close to that of the human eye and detects in the vicinity of 500 nm with highest sensitivity. The sensitivity is better with blue light than with red light and also, a brighter image can be captured with blue light than with red light. This is why blue light is suitable to capture a bright image with a high-speed shutter and large depth of field.

Blue 460 nm/spectral sensitivity approx 90%
 Red 660 nm/spectral sensitivity approx 60%
 Blue light is 1.5 times brighter than red light.

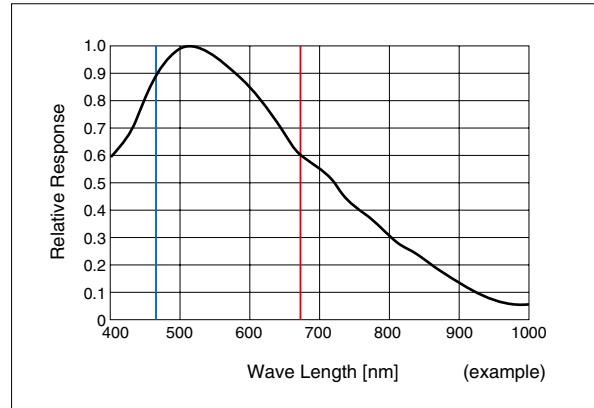

Strobe lighting & wiring

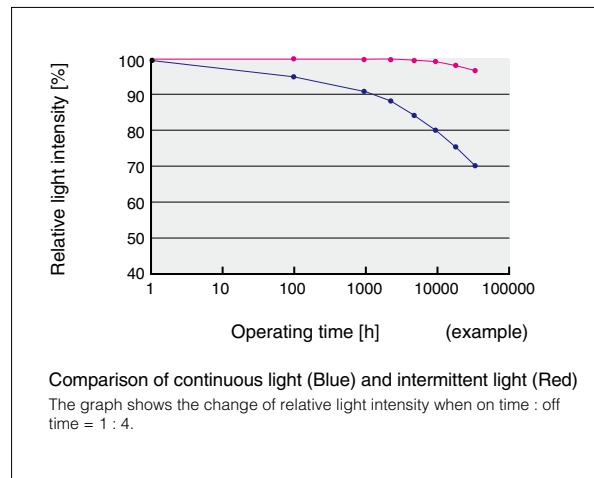
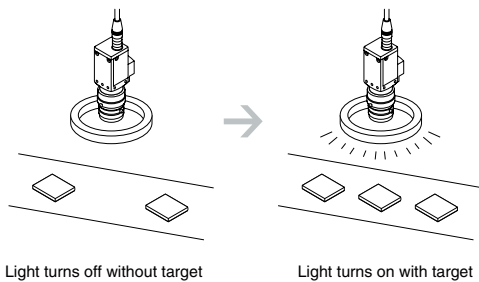

Effects of intermittent lighting & wiring

The service life becomes longer when the ratio of off time to on time increases. High-speed blinking does not burden LED elements. When off time is 4 times longer than on time, the service life lasts 5 times longer than that of continuous light.

Example of wiring for intermittent lighting

Connection of the CA-DC100 controller to the CV-5000 Series.

LED illumination lights intermittently when input is received from the CV-5000 Series.

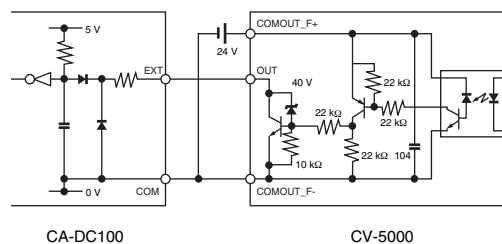

The effect of a polarization filter

A polarization filter transmits only a light wave in a specified direction. Regular reflections from a glossy surface can be eliminated when polarization filters are mounted on the lens and the illuminator as shown in the illustration.

Principle

The light 1 is polarized with the polarization filter A and becomes polarized light 2. The glass surface specularly reflects light 2. The specular reflection 3 is intercepted by the polarization filter B while the target surface diffusely reflects light 4. The diffuse reflection 4 is polarized by the polarization filter B and only the polarized light 5 enters into the camera.

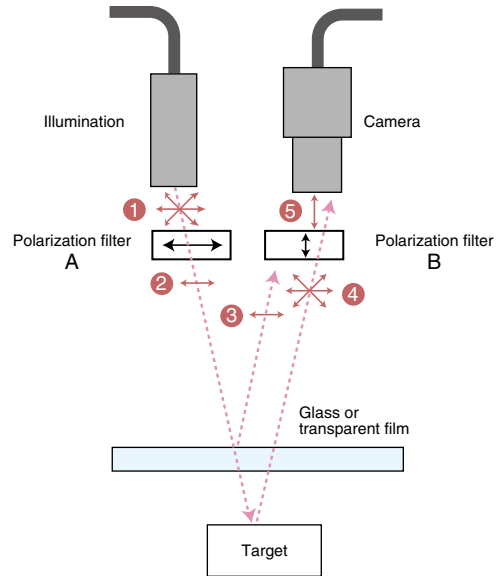

Without polarization filter
The CD case reflects the illumination.



With polarization filter
The polarization filter reduces the reflection.

Specifications

LENS	TYPE	MODEL	NOTE
CV-L	27 mm 1.06° 30.5 mm 1.20°	OP-54029 OP-54030	Screw diameter OP-54029 27 mm 1.06° OP-54030 30.5 mm 1.20°
CV-LH	25.5 mm 1.00° 27 mm 1.06°	OP-51603 OP-54029	Screw diameter OP-51603 25.5 mm 1.00° OP-54029 27 mm 1.06°
CA-LHS	16 mm 0.63°	OP-66832	
CA-LS	12 mm 0.47°	OP-51502	

Dimensions

Unit: mm inch

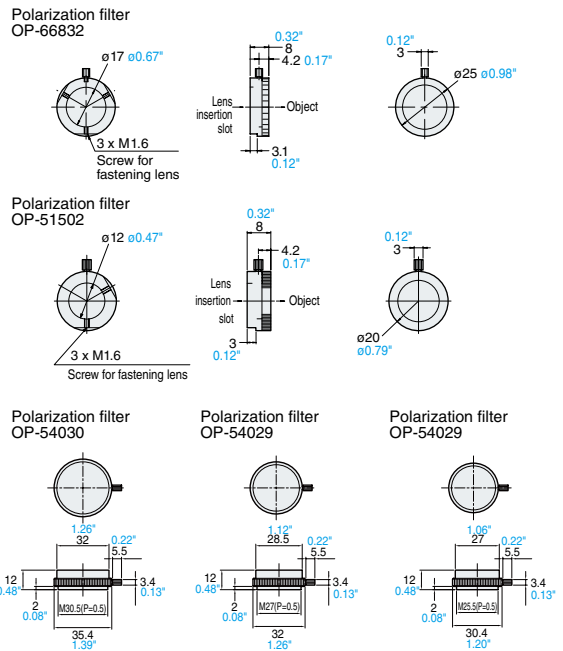

Options

For glare prevention

Eliminates glare of glossy targets together with the lens polarizing filter. (Compatible with direct-ring light and bar lights)

MODEL	Compatible illuminator
OP-42280	CA-DBx13
OP-42281	CA-DBx5
OP-42336	CA-DRx4F
OP-42338	CA-DRx10F

Polarizer

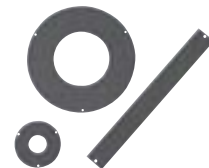

* Portection filter ► p.51

Direct reflection and diffuse reflection

Object surfaces have a variety of colors and reflections, and surface gloss is especially important to determine lighting angle. A glossy surface specularly reflects the light and a matte surface diffuses the light. A glossy surface can appear bright or dark by changing position of the illuminator and the camera.

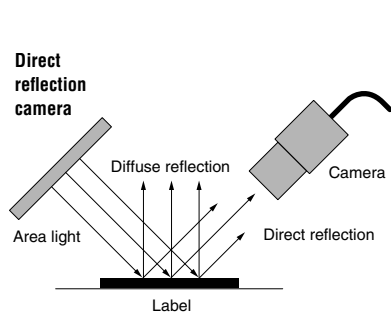

The glossy background of the label appears bright and the print appears dark as it diffusely reflects the light.

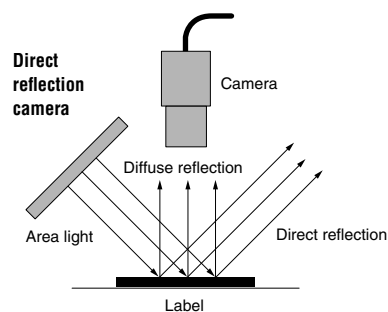

The glossy background of the label appears dark and the print appears bright.

Features & data of various LEDs

Service life Service lives of different lamps (example)

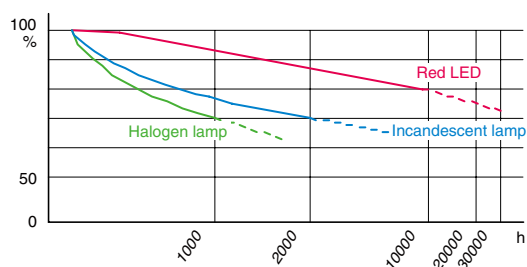

Wavelength Emission wavelength/spectral distribution (example)

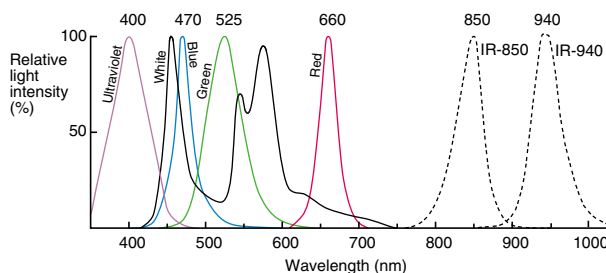

Heat and deterioration of light intensity (example)

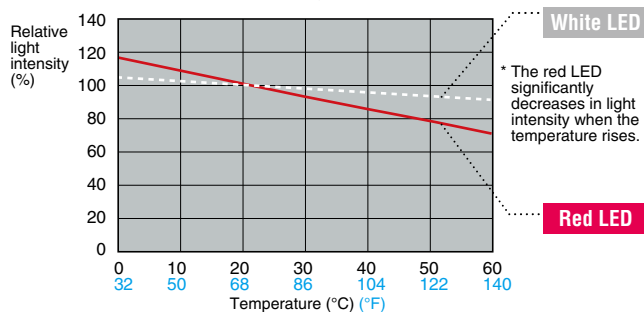



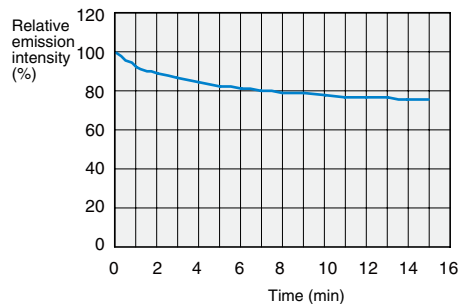

Initial drift LED initial drift (example)



Lens Options

Selection Guide

Model	Description	5M Pixels	2M Pixels	310K Pixels	2M Pixels Ultra Small	310K Pixels Ultra Small	Application	Page
		CV-H500C CV-H500M	CV-200C/M CV-H200C/M	CV-035C/M CV-H035C/M	CV-S200C CV-S200M	CV-S035C CV-S035M		
CA-LM 	Macro Lens	○	○	○	—	—	High-accuracy measurement of minute targets	P.46
CA-LH 	High-resolution & Low distortion Lens	○	○	○	—	—	High-accuracy size measurement	P.47
CA-LS 	Super Small Lens	—	—	—	—	○	Space saving	P.50
CA-LHS 	High-resolution Small Lens	—	—	—	○	—	High-accuracy and space saving	P.50
CV-L 	Standard Lens	—	○	○	—	—	General purpose	P.48

Technical Information

Focal distance and lens _____ **P.49**

Distortion _____ **P.49**

Aperture diaphragm and depth of field _____ **P.51**

Protection filter _____ **P.51**

Macro Lens CA-LM Series

0.5x-1.0x
CA-LM0510

CA-LM2

CA-LM4

CA-LM6

CA-LM8

Telecentric lenses yield small measurement errors

A telecentric lens has an optical system designed to allow principal rays to pass the focal point. Principal rays pass through the lens in parallel with the optical axis as shown in Figure 2. Consequently, the angle of view is 0°. One of the advantages of telecentric lenses is that the change in the target position causes less change in the size of the captured image, resulting in accurate dimension measurement. A telecentric lens is suitable for dimension measurement or positioning of targets with some height variation.

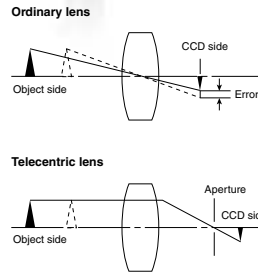
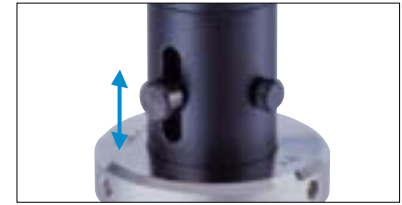

Figure 2



Fine magnification adjustment feature

Even though the magnification is fixed, the lens features a fine adjustment that enables delicate adjustment of back-focus error.

0% TV distortion

In spite of its compact design, TV distortion is eliminated, enabling highly accurate measurement across the entire FOV.

Telecentric effect

Telecentric lens
CA-LM2
(2.0x optical magnification)

Distance from the camera

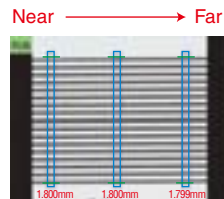

With a telecentric lens, the 2.5 mm 0.10" height differential causes only a minimal amount of dimensional variation.

Standard CCTV low distortion lens
50 mm 1.97" lens
(with 95-mm 3.74" close-up ring)

Distance from the camera

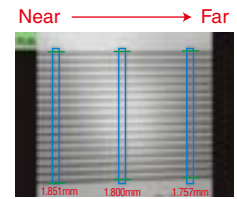

With a CCTV lens, the measurement is affected by the height difference. As the target moves away from the lens, the dimensional measurement becomes smaller.

Specifications

MODEL	CA-LM0510	CA-LM2	CA-LM4	CA-LM6	CA-LM8	
Shape	Straight					
Optical magnification (Reference magnification)	x0.5-x1	x2	x4	x6	x8	
Allowable variation in magnification	Approx. ±5% of the reference magnification					
WD (With the reference magnification)	x0.5: 111 mm 4.37" x1.0: 78 mm 3.07"	66.9 mm 2.63"	70.3 mm 2.77"	64.4 mm 2.54"	64.5 mm 2.54"	
Maximum size of applicable image	2/3-inch CCD		1/2-inch CCD			
Imaging field of view (With the reference magnification)	1/3-inch CCD	3.6 x 4.8 mm to 7.2 x 9.6 mm 0.14" x 0.19" to 0.28" x 0.38"	1.8 x 2.4 mm 0.07" x 0.09"	0.9 x 1.2 mm 0.04" x 0.05"	0.6 x 0.8 mm 0.02" x 0.03"	0.45 x 0.6 mm 0.18" x 0.02"
	1/2-inch CCD	4.8 x 6.4 mm to 9.6 x 12.8 mm 0.19" x 0.25" to 0.38" x 0.50"	2.4 x 3.2 mm 0.09" x 0.13"	1.2 x 1.6 mm 0.05" x 0.06"	0.8 x 1.07 mm 0.03" x 0.04"	0.6 x 0.8 mm 0.02" x 0.03"
Effective F No.	2.8 to CLOSE		15.4	26.5	39.3	52.4
Depth of field	x0.5	2560 μm 99.8 Mil	400 μm 15.6 Mil	172 μm 6.7 Mil	111 μm 4.33 Mil	79 μm 3.08 Mil
	x1.0	1280 μm 49.9 Mil				
TV distortion (Max.)	x0.5	-0.4%	-0.04%	-0.22%	-0.10%	-0.04%
	x1.0	-0.1%				
Resolution	x0.5	3.8 μm 0.15 Mil	5.1 μm 0.20 Mil	4.5 μm 0.18 Mil	4.4 μm 0.17 Mil	4.4 μm 0.17 Mil
	x1.0	3.4 μm 0.13 Mil				
Mount	C-mount					
Ambient temperature and relative humidity	0 to +50°C (0 to 122°F), 80% (No condensation)					
Weight	Approx. 220 g	Approx. 57 g	Approx. 58 g	Approx. 64 g	Approx. 67 g	

- * The value of the depth of field is obtained with theoretical calculation on the assumption of a 1/2" image size and a horizontal resolution of 320 TV lines. (The minimum circle of confusion on the image side: 40 μm 1.57 Mil)
- * The resolution is a theoretical value at a distance of 550 nm.
- * The ranges of the imaging field of view indicate the reference field of view of each image size. The value can be modified by approx. ±5% by adjusting the magnification.
- * The values of WD indicate the working distance when each lens is used with reference magnification, and they will change by adjusting the magnification.
- * The values in the specifications above are obtained based on the optical design value, and individual differences are generated depending on the assembly accuracies.

Dimensions

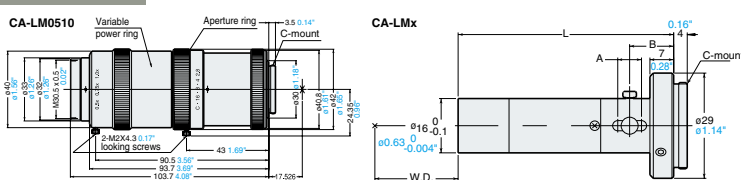

	CA-LM2	CA-LM4	CA-LM6	CA-LM8
L (Length)	63.5 2.50"	69.3 2.73"	80.6 3.17"	95.0 3.56"
A (Adjustable range)	7.0 0.28"	9.3 0.37"	7.7 0.30"	7.6 0.30"
B (Adjustable position)	13.0 0.51"	15.1 0.59"	20.5 0.81"	34.9 1.37"
C (Coaxial position)	30.7 1.21"	31.8 1.25"	-	-

High-Resolution & Low Distortion Lens CA-LH Series

CA-LH8



CA-LH16



CA-LH25



CA-LH50



Low optical distortion [BEST IN ITS CLASS]

An original optical design has been adopted to eliminate distortion, which is often the largest obstacle for dimensional measurements and other applications requiring high accuracy. The CA-LH Series has a low distortion level of 0.01% or lower.*

* When using the CA-LH50

High resolution and high contrast

The floating mechanism moves the front and rear spherical elements separately, obtaining high resolution from close range to infinity. In addition, the contrast is improved dramatically from conventional products. Even targets with small intensity contrasts can be reproduced reliably without being washed out in the background.

Large focus range

Using lens extenders/spacers to bring smaller targets in focus can be a hassle when setting up a machine vision application. The CA-LH Series provides an extremely long focus range, which allows for easy camera adjustment during product changeovers.

Comparison of distortion

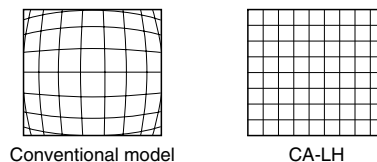

Comparison of magnified images

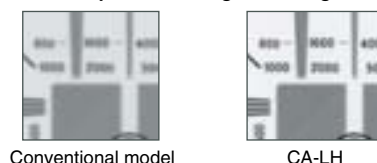
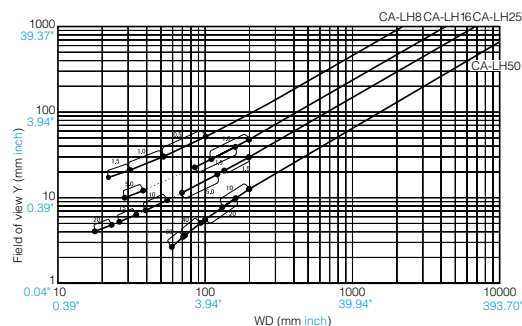

Chart of field of view



When the CV-035/020/070 is attached, the values on the chart are reference values. Adjustments may be required for installation.

List of models: specifications of the CA-LH Series

MODEL	CA-LH8	CA-LH16	CA-LH25	CA-LH50
Focal distance	8 mm 0.31"	16 mm 0.63"	25 mm 0.98"	50 mm 1.97"
Aperture	F1.4 to F16	F1.4 to F16	F1.4 to F16	F2.8 to F22
Minimum close-up distance	0.1 m 0.33'	0.2 m 0.66'	0.2 m 0.66'	0.2 m 0.66'
Mount	C-mount			
Screw diameter of filter	27.0 mm 1.06" P0.5	25.5 mm 1.01" P0.5	27.0 mm 1.06" P0.5	27.0 mm 1.06" P0.5
Maximum size of applicable image	2/3-inch CCD			
TV distortion*	-0.6% (-0.28%) max.	-0.05% (-0.1%) max.	-0.04% (-0.02%) max.	-0.03% (-0.01%) max.
Ambient temperature and relative humidity	0 to 50°C (32 to 122°F), 80% (No condensation)			
Weights	Approx. 83 g	Approx. 81 g	Approx. 89 g	Approx. 92 g

* Indicates the values of 2/3-inch CCD. The values in parenthesis are for 1/3-inch CCD. Notes: When connecting the CA-LH8 with a camera other than the CV-035/200/020/500, a close-up ring of 1.5 mm 0.06" or more is required.

List of options

Type	Model	Remarks
Close-up ring set for the CA-LH	OP-51612	Thickness: 0.5 mm, 1 mm, 5 mm, 10 mm, 22 mm 0.02", 0.04", 0.20", 0.39", 0.87"
Polarizing filter 25.5	OP-51603	For a 25.5-mm 1.00" screw diameter
Polarizing filter 27	OP-54029	For a 27-mm 1.06" screw diameter

Dimensions

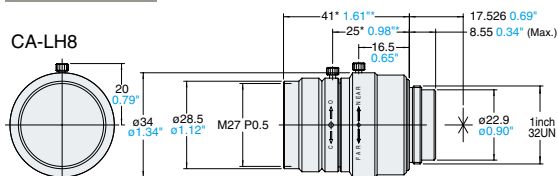

* Variable depending on the focal distance. Extension amount: 0 to 1.2 mm 0 to 0.05"

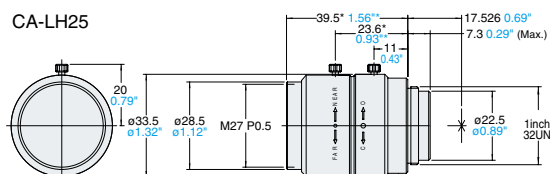

* Variable depending on the focal distance. Extension amount: 0 to 4.5 mm 0 to 0.18"

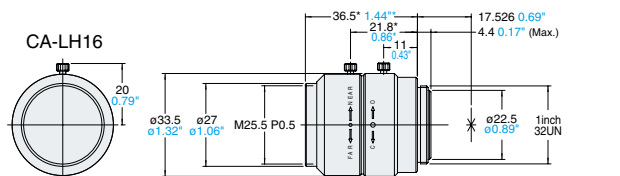

* Variable depending on the focal distance. Extension amount: 0 to 4.5 mm 0 to 0.18"

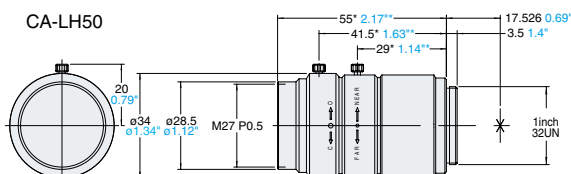

* Variable depending on the focal distance. Extension amount: 0 to 18.5 mm 0 to 0.73"

CCTV Lens CV-L Series

General-purpose, Compact Size CCTV Lens



Chart of field of view

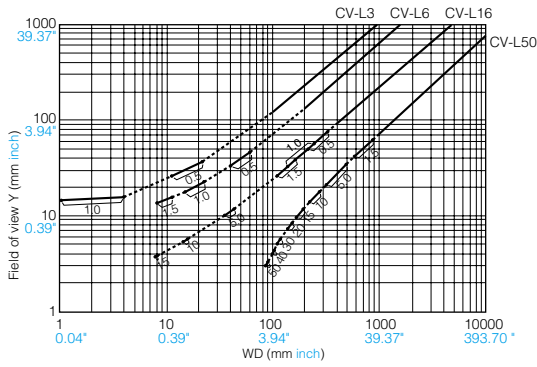

When the CV-035/020/070 is attached, the values on the chart are reference values. Adjustments may be required for installation.

List of models

Type	Model	Focal distance
Standard	CV-L16	16 mm 0.63"
	CV-L3	3.5 mm 0.14"
Wide-angle	CV-L6	6 mm 0.24"
	CV-L50	50 mm 1.97"
Polarizing filter 27 Polarizing filter 30.5	OP-54029	For a 27-mm screw diameter 1.06"
	OP-54030	For a 30.5-mm screw diameter 1.20"
Close-up ring set	OP-51612	Thickness: 0.5 mm, 1 mm, 0.04" 0.02" 5 mm, 10 mm, 22 mm 0.87" 0.39" 0.20"

Dimensions

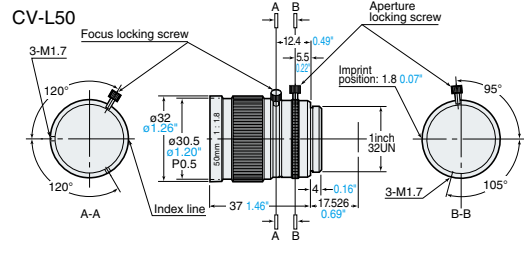
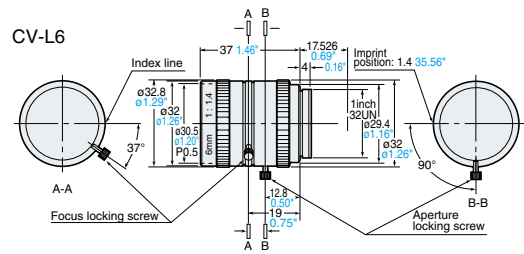
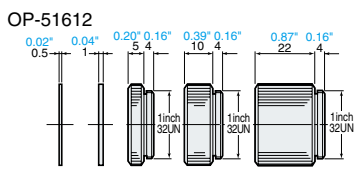
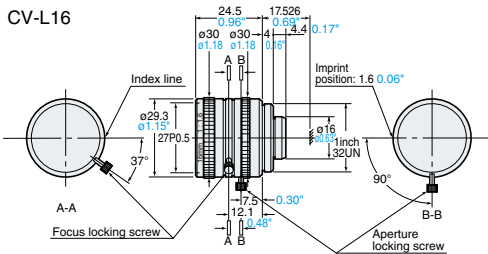
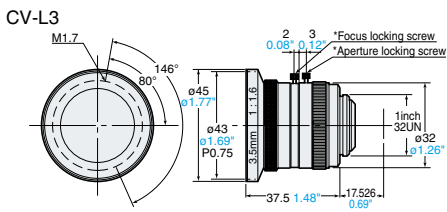

Unit: mm inch

EFFECTIVE USE OF LENSES

Focal distance and lens

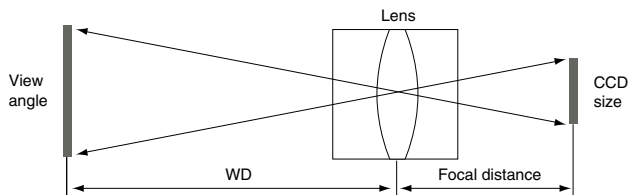

The size of the WD and the view angle are determined by the focal distance and the CCD size. When NOT using a closeup ring, the following proportional expression can be applied.

$$\frac{\text{Working Distance}}{\text{View angle}} = \frac{\text{Focal distance}}{\text{CCD}}$$

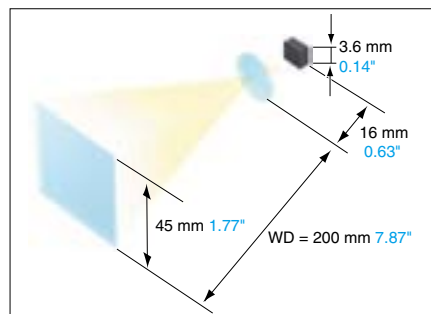

When the focal length is 16 mm 0.63" and the CCD size is 3.6 mm 0.14", WD should be 200 mm 7.87" to make the view angle at 45 mm 1.77".

$$WD = 16 \times 45 / 3.6 = 200 \text{ mm (7.87")}$$

The graph on the left (visual field graph) shows the relationship between the focal distance, the working distance (WD), and the visual field. A suitable lens can be determined based on the intersection of WD and visual field. If an object is placed at a distance shorter than the minimum focal distance of the lens, attach a close up ring or spacer for a close shot. The solid lines between the dots in the visual field graph indicate the size of the close up ring.

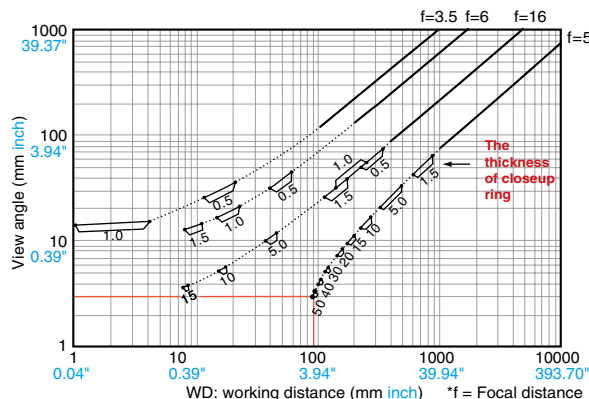

When mounting a closeup ring of 50 mm (1.97") on a 50 mm (1.97") lens, the user can capture an image with a view of 3 mm (0.12") at WD = 90 mm (3.54"). (Intersection of red lines)

Distortion

What is distortion?

Distortion is the ratio of the change between the center and edge areas of a captured image. Due to the aberration of the lens, the distortion is more noticeable at the edges of a captured image. There are two types of distortion: barrel distortion and pincushion distortion. The general rule is that when the absolute value of the distortion value is smaller, the lens offers higher accuracy.

Reference: Distortion values

Focal distance	CA-LH Series			Comparison with conventional models	Conventional lens		
8 mm 0.31"/ 6 mm 0.24"	CA-LH8	-0.28%	○	2.1 times higher accuracy	CV-L6	-0.60%	△
16 mm 0.63"	CA-LH16	-0.10%	○	6 times higher accuracy	CV-L16(CV-LC16)	-0.60%	△
25 mm 0.98"	CA-LH25	-0.02%	◎	-	-	-	-
50 mm 1.97"	CA-LH50	-0.02%	◎	16 times higher accuracy	CV-L50	0.16%	△

* Typical values obtained with 1/3-inch CCD

Barrel distortion

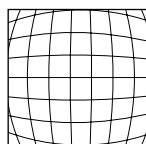

Pincushion distortion

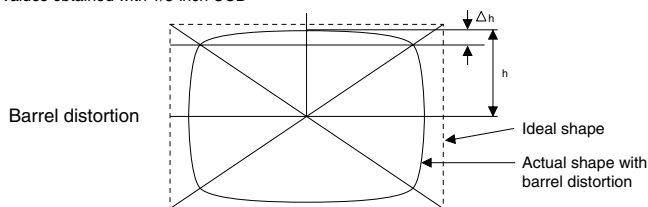
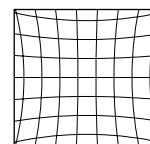

Calculating formula

$$TV \text{ distortion (Dtv)} = \Delta h / 2h \times 100 (\%)$$

A positive value of TV distortion indicates pincushion distortion and a negative value indicates barrel distortion.

CA-LS Series CV-S035C/CV-S035M dedicated lens

High-resolution lens



Close-up-ring

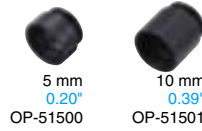

Polarization filter



Side viewer attachment



CV-S035C/CV-S035M
(When CA-LS Series is installed)

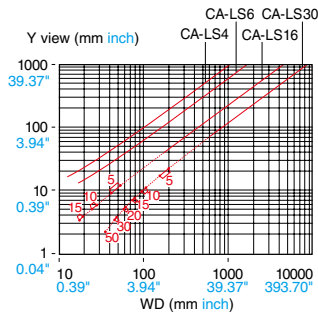

Lens CA-LSx

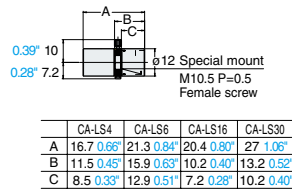

Dimensions

Unit: mm inch

Side view attachment
OP-51503

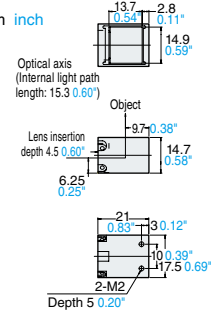
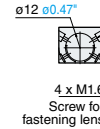

CA-LHS Series CV-S200C/CV-S200M dedicated lens

High-resolution lens



Close-up-ring

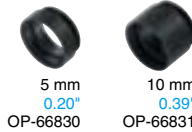

Polarization filter



Side viewer attachment



CV-S200C/CV-S200M (When CA-LHS Series is installed)

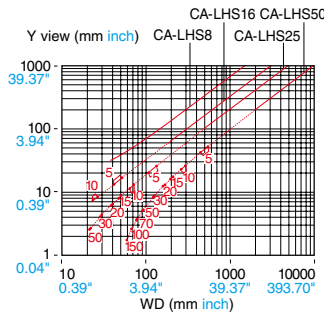

Lens CA-LHSx

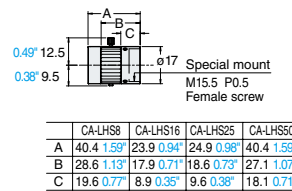

Dimensions

Unit: mm inch

Side view attachment
OP-66833

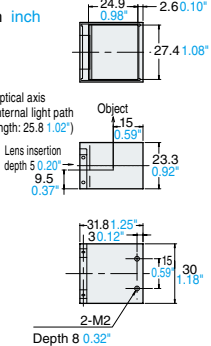
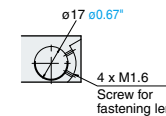

Mounting space can be reduced even more when using the side-view attachment

The side-view attachment with a built-in precision mirror enables sensor-like lateral mounting, significantly improving the mounting flexibility.



Mounting the camera inside a packaging machine



Detecting missing print

Significant decrease in mounting space

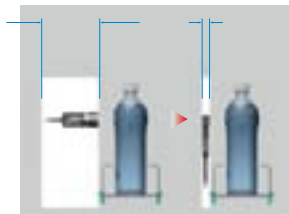

Required mounting space is decreased to one-tenth.

Detecting a wafer notch



Collisions with moving mechanical components caused by the large size of conventional cameras can be eliminated.

EFFECTIVE USE OF LENSES

Aperture diaphragm and depth of field

The depth of field is the range in which a lens can focus on objects. So, a lens with a large depth of field can focus on a target which moves in the direction of the lens.

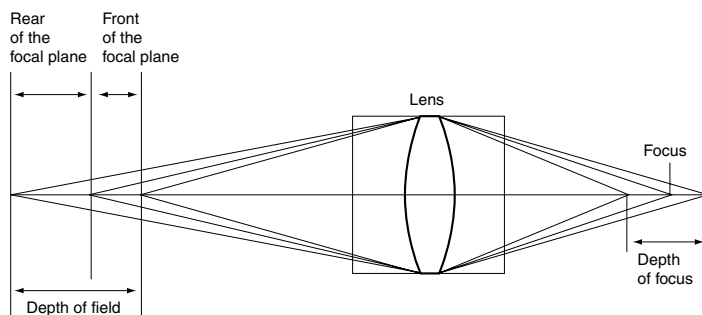

< Depth of field >

- (1) The shorter the focal distance, the larger the depth of field.
- (2) The longer the distance from the lens to the object, the larger the depth of field. Closeup rings and macro lenses make the depth of field smaller.
- (3) The smaller the aperture, the larger the depth of field. Small aperture and bright illumination make focusing easy.

A camera is installed as shown in the illustration. A graduated tape that indicates the height is attached on a slope. In this condition, the pictures are taken for comparison of aperture.



When the aperture is closed (CA-LH25)



When the aperture is open (CA-LH25)

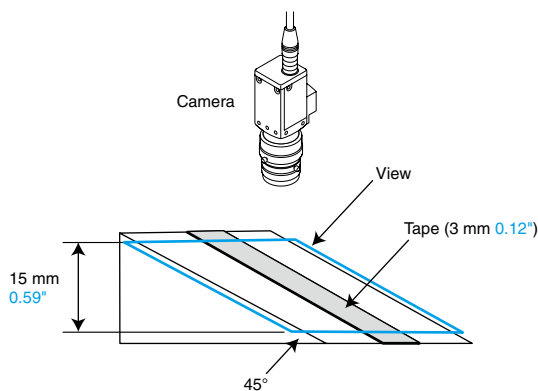

Protection filter



Name	Model	Compatible lens
Protection filter 25.5 mm 1.00"	CA-LF25	CA-LH16
Protection filter 25.5 mm 1.00"	CA-LF27	CA-LH8/CA-LH25/CA-LH50/ CV-L16/CA-LC16
Protection filter 30.5 mm 1.20"	CA-LF30	CV-L6/CV-L50/CA-LM0510

Features of lens protection filter

- Prevents damage to the lens while maintenance is performed on the machine.
- Since the cover is easily removed and cleaned, lens maintenance time is reduced.
- Prevents machining swarf from damaging the lens.
- Protects the lens from abrasive metal particles and oil/dirt.

* Polarization filter ▶ p.43

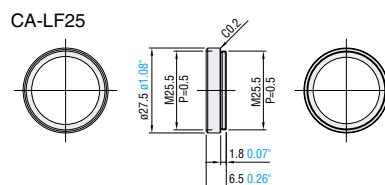
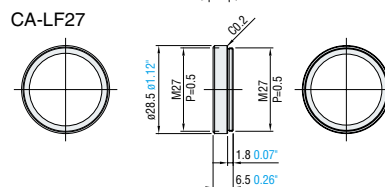
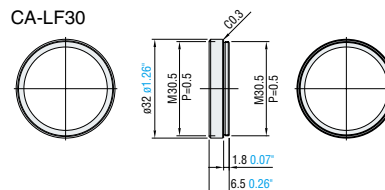

Dimensions

Unit: mm inch



Monitors

Selection Guide

Model	Description	Resolution	CV-5000	CV-701	Color	Page
CA-MP81 	8.4" LCD color Monitor	SVGA (800 X 600)	○	—	○	P.53
CA-MN81 	8.4" LCD color Monitor	NTSC (640 X 480)	—	○	○	P.53
CV-M30 	5.5" LCD color Monitor	NTSC (640 X 480)	—	○	○	P.54

Peripheral Equipment

Model	Description	Page
CA-U3 	24 VDC Power Supply Unit	P.55
CA-S2040 	Camera Adjustment Stage	P.55

8.4" LCD Monitor CA-MP81/MN81



When mounted on the special stand

Ultra slim, space-saving design

Ultra slim design with a thickness of 40 mm **1.57"** facilitates installation on a control panel.

IP65 rated environmental resistant specifications

Environmental resistant specifications are provided for protecting the monitor from splashes of water or powder dust.

High-intensity and high-definition color TFT-LCD

The TFT active-matrix system is employed to realize a bright screen and high-definition display with 262,144 colors.

Wide range of mounting options

In addition to the options for panel-mounting, a special stand and pole-mounting bracket are also available for a wide variety of mounting styles.

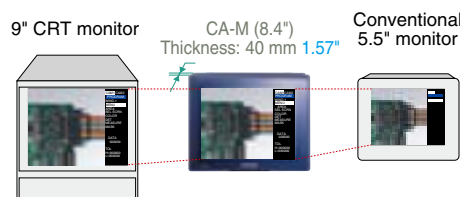

Special stand with holes for locking screws (OP-42278)



Pole-mounting bracket Enables installations on any round bars (OP-42279)

Specifications

NTSC composite signal (1.0 Vp-p, 75 Ω)



Model	CA-MP81	
Display panel	Display element	a-Si, TFT active matrix method
	Display color	262144
	No. of dots	800 (W) x 600 (H) dots
	Active display area	170.4 (W) x 127.8 (H) mm 6.71" x 5.03"
Backlight	Drive system	One-way cold cathode fluorescent tube
	Operating life	Approx. 50000 hours (average) (When installed in an upright position under 25°C (77°F))
Input/Output	Input signal	Analog RGB signal (0.7 Vp-p, 75 Ω), Horizontal/vertical synchronization signal
	Input signal mode	800 (W) x 600 (H) 31.50" x 23.63" , Vertical frequency: 60 Hz
	Connector	High-density D-sub 15-pin female (3-way, inch screw)
Power supply voltage	24 VDC ±10%	
Current consumption	1 A max.	
Ambient temperature	0 to 40°C (32 to 104°F)	
Relative humidity	35 to 85%	
Construction	Panel-mount type - only the front face is dust-proof and splashproof equivalent to IP65	
Weight	Approx. 1200 g	

* Optional: Monitor cable (3M) **9.8'** OP-66842

Model	CA-MN81	
Display panel	Display element	a-Si, TFT active matrix method
	Display color	262144
	No. of dots	800 (W) x 600 (H) dots NTSC signals are displayed on full screen by scaling.
	Active display area	170.4 (W) x 127.8 (H) mm 6.71" x 5.03"
Backlight	Drive system	One-way cold cathode fluorescent tube
	Operating life	Approx. 50000 hours (average) (When installed in an upright position under 25°C (77°F))
Input/Output	Input signal	NTSC composite signal (1.0 Vp-p, 75 Ω)
	Connector	RCA pin-jack (1 each for In and Out)
Power supply voltage	24 VDC ±10%	
Current consumption	1 A max.	
Ambient temperature	0 to 40°C (32 to 104°F), No freezing	
Relative humidity	35 to 85%, No condensation	
Construction	Panel-mount type - only the front face is IP65-rated dustproof and splash-proof construction.	
Weight	Approx. 1200 g	

Dimensions

Unit: mm inch

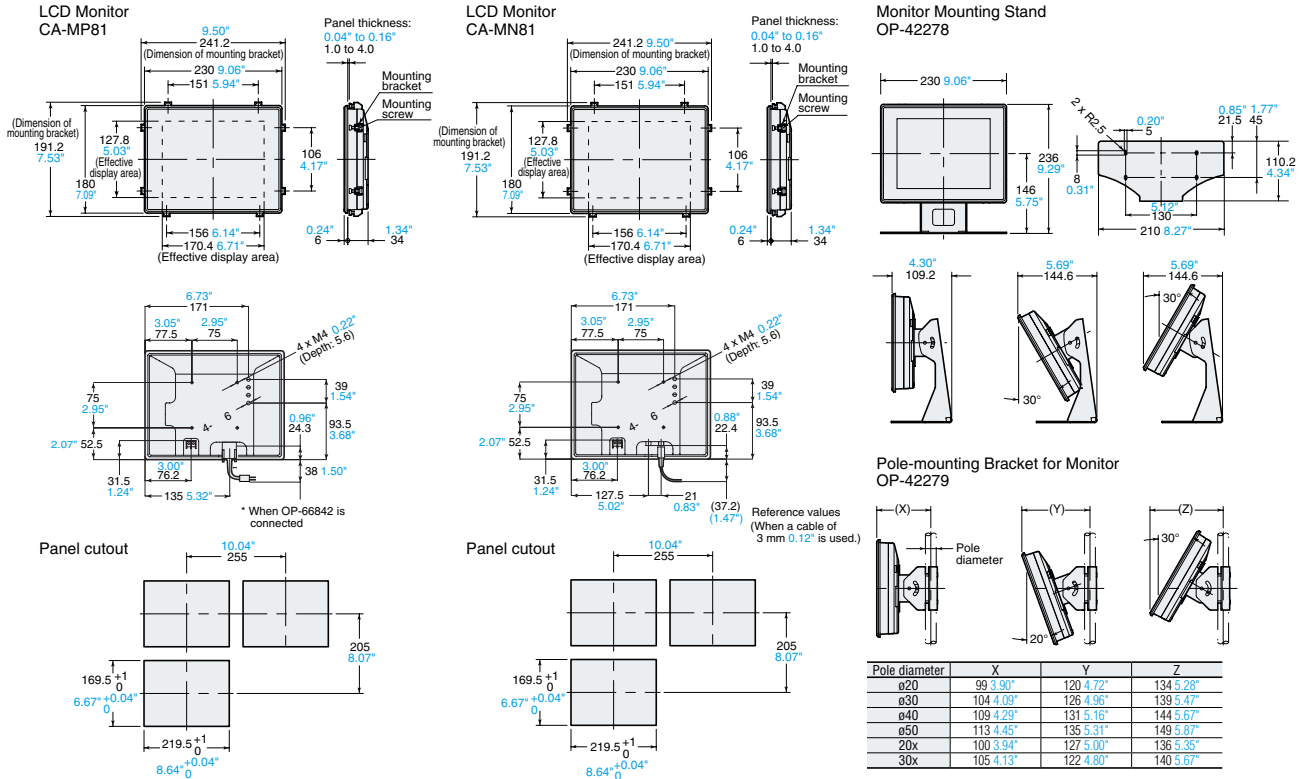

5.5" LCD Color Monitor CV-M30

Specifications



MODEL		CV-M30
LCD panel	Display screen size	5.5", 111.36 (W) x 85.52 (H)mm 4.38" x 3.37"
	No. of dots	320 (W) x 240 (H)dots
	Display color	Full color
	Drive system	TFT active-matrix system
Video input	NTSC composite signal 1.0 Vp-p 75 Ω	
Power supply voltage	24 VDC ±10%	
Current consumption	700 mA max.	
Ambient temperature	0 to 40°C (32 to 104°F), No condensation	
Relative humidity	35 to 85%, No condensation	
Weight	Approx. 570 g	



Dimensions

Unit: mm inch

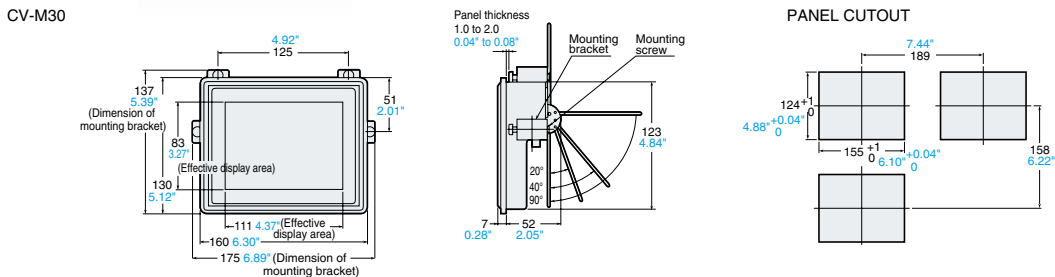

24 VDC Power Supply Unit CA-U3



Specifications



MODEL		CA-U3
Input conditions	Rated input voltage	100 to 240 VAC ($\pm 10\%$), 50/60 Hz
	Efficiency	78 to 80% (typical)
	Rated input current	2.1 A max.
	Power factor (100/200 VAC)	0.99/0.95 (typical) with maximum load applied
	Leakage current (100/200 VAC)	0.4/0.75 mA max.
	Rush current (100/200 VAC)	18/36 A max. (at 25°C (77°F) cold start)
Output conditions	Oversoltage category	II
	Rated output voltage	24 VDC
	Rated output current	6.0 A (Total of 3 output terminals)
	Ripple/noise voltage	1% (p-p) max.
	Input fluctuation	0.4% max.
	Load fluctuation	0.7% max.
	Starting time (100/200 VAC)*1	1300/700 ms max.
	Output holding time	20 ms min. (100 to 240 VAC)
Protection	Oversoltage*2	Constant current drops or output is cut off at 7.9 A or higher.
	Oversoltage*3	Provided
Ambient temperature		-10 to +55°C (14 to 131°F) (No freezing) (Refer to derating characteristics)
Relative humidity		-20 to +70°C (-4 to +158°F) (No freezing)
Pollution level		2
Withstand voltage		3.0 KVAC 50/60 Hz/1 min (Input-output) 2.0 KVAC 50/60 Hz/1 min (Input-GND) 500 VDC/1 min (Output-GND)
Impact resistance		300 m/s ² , 2 times for each direction of 3 axes
Vibration resistance		10 to 55 Hz, Double amplitude of 1.5 mm 0.06" max. 2 hours each in X, Y, and Z directions (9.8 m/s ² max. when mounted on a DIN-rail)
Insulating resistance		100 M Ω min. at 500 VDC (Input-output) (Input-GND) (Output-GND)
Safety standards		UL60950-1, UL508, CAN/CSA C-22.2 60950-1-3, EN60950, EN60950-1
Noise terminal voltage		FCC part 15B class A, EN55011 class A
Radiated interference field strength		FCC part 15B class A, EN55011 class A
Limits for harmonic current emissions		Conforms to EN61000-3-2.
Weight		Approx. 700 g

- *1: Specified with the rated input voltage (100 or 200 VAC) and 100% load applied.
- *2: Automatic recovery occurs after dropping. When output is interrupted, wait for 1 minute or longer after the input is turned off, and then turn on the input for recovery.
- *3: Output is cut off by an amplitude interrupting system. When output is interrupted, wait for 1 minute or longer after the input is turned off, and then turn on the input for recovery.

Dimensions

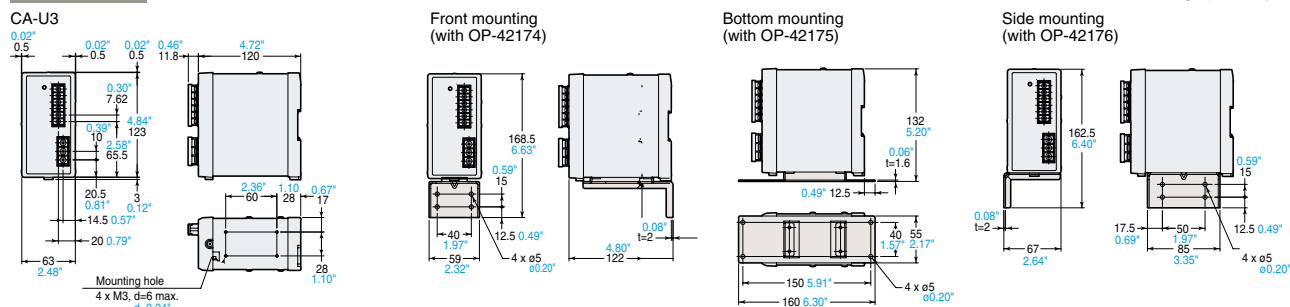

Camera Adjustment Stage CA-S2040



A compact and light XY stage mounted between the camera and the base. It allows easy, fine adjustment of the camera position when a high magnification lens is used.



Dimensions

Unit: mm inch

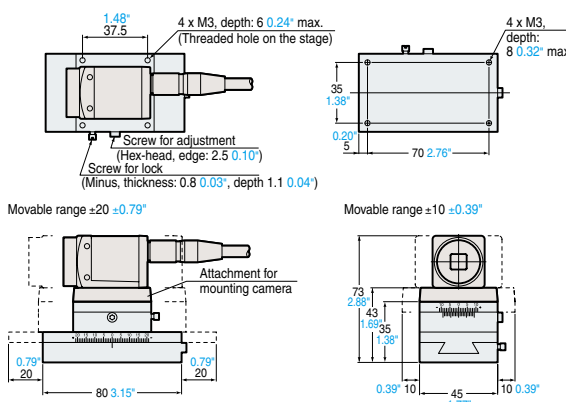

Specifications

MODEL		CA-S2040
Shift amount	Short axis	± 10 mm $\pm 0.39"$
	Long axis	± 20 mm $\pm 0.79"$
Scale display		Display resolution 1 mm 0.04" (0.1 mm 0.004" with a vernier scale)
Thread pitch		0.7 mm 0.03"/turn (both short and long axes)
Maximum load		1.5 kgf
Lock mechanism		Locking screw fixing, appropriate tightening torque: 30 cN·m
Environmental resistance	Operating ambient temperature	0 to 50°C (32 to 122°F)
	Operating ambient humidity	35 to 85% RH (No condensation)
Weight		250 g



Your online portal to...

A complete knowledge center to assist you with all of your Machine Vision needs

Get Useful Technical Literature FREE!



Would you like to learn more about today's Vision Technology?

MACHINE VISION TECHNOLOGY

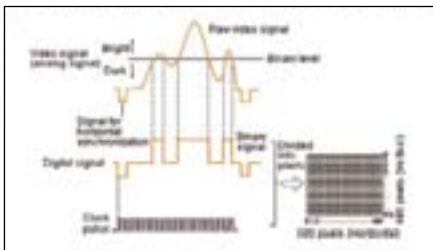

Visionssystem.com has a vast database of technical resources to help beginners and experts learn more about effectively implementing machine vision technology.

www.visionssystem.com/technology

Beginner's Help Ask the Experts

Our experts are ready to answer your questions on vision applications.

www.visionssystem.com/consult

Not sure which vision system is right for you?

APPLICATIONS



Let KEYENCE help you determine the ideal vision solution to your specific application.

www.visionssystem.com/applications

Support Software
CV 3000 Series Network Communications Software

Free!

Data Acquisition and CV Simulator software. CV 3000 programs can be transferred to a PC and then used for optimal performance. Operational data such as inspection measurements and images can be collected, displayed, and saved on a PC as well.

Get Software with Unlimited Duration Download

Watch Help Files for using the CV 3000 CV Simulator

Get CV 3000 Series Software and Manuals Download CV

Acquisition Programs and Images Saved on a Memory Card

Communications with a CV 3000 Series Controller

www.visionssystem.com/support

Specifications are subject to change without notice.



CALL TOLL FREE

TO CONTACT YOUR LOCAL OFFICE
1-888-KEYENCE
1 - 8 8 8 - 5 3 9 - 3 6 2 3

www.keyence.com
Fax : 201-930-0099

KEYENCE CORPORATION OF AMERICA

Corporate Office	50 Tice Blvd., Woodcliff Lake, NJ 07677	Phone:201-930-0100	Fax:201-930-0099	E-mail:keyence@keyence.com																												
Regional offices	<table border="0"> <tr> <td>CO Denver</td> <td>IN Indianapolis</td> <td>MI Detroit</td> <td>NJ Woodcliff Lake</td> <td>OH Cincinnati</td> <td>SC Greenville</td> <td>VA Richmond</td> </tr> <tr> <td>AL Birmingham</td> <td>FL Tampa</td> <td>KS Kansas City</td> <td>NY Rochester</td> <td>OH Cleveland</td> <td>TN Nashville</td> <td>WA Seattle</td> </tr> <tr> <td>CA N. California</td> <td>GA Atlanta</td> <td>KY Louisville</td> <td>MN Minneapolis</td> <td>OR Portland</td> <td>TN Knoxville</td> <td></td> </tr> <tr> <td>CA Los Angeles</td> <td>IL Chicago</td> <td>MA Boston</td> <td>MO St. Louis</td> <td>NC Charlotte</td> <td>PA Philadelphia</td> <td>TX Dallas</td> </tr> </table>	CO Denver	IN Indianapolis	MI Detroit	NJ Woodcliff Lake	OH Cincinnati	SC Greenville	VA Richmond	AL Birmingham	FL Tampa	KS Kansas City	NY Rochester	OH Cleveland	TN Nashville	WA Seattle	CA N. California	GA Atlanta	KY Louisville	MN Minneapolis	OR Portland	TN Knoxville		CA Los Angeles	IL Chicago	MA Boston	MO St. Louis	NC Charlotte	PA Philadelphia	TX Dallas			
CO Denver	IN Indianapolis	MI Detroit	NJ Woodcliff Lake	OH Cincinnati	SC Greenville	VA Richmond																										
AL Birmingham	FL Tampa	KS Kansas City	NY Rochester	OH Cleveland	TN Nashville	WA Seattle																										
CA N. California	GA Atlanta	KY Louisville	MN Minneapolis	OR Portland	TN Knoxville																											
CA Los Angeles	IL Chicago	MA Boston	MO St. Louis	NC Charlotte	PA Philadelphia	TX Dallas																										

KEYENCE CANADA INC.

Head Office Phone:905-696-9970 Fax:905-696-8340 E-mail:keyence@keyence.com
Montreal Phone:514-694-4740 Fax:514-694-3206

KEYENCE MEXICO S.A. DE C.V.

Phone:+52-81-8220-7900 Fax:+52-81-8220-9097
E-mail:keyencemexico@keyence.com